

SECTION 10211

METAL WALL LOUVERS

PART 1 – GENERAL

1.01 REFERENCES

- A. AMCA 500 (Air Movement Control Association) – Test Method for Louvers, Dampers, and Shutters.
- B. ASTM A167 – Stainless and Heat-Resisting Chromium-Nickel Steel Plate.
- C. ASTM A653 – Steel Sheet, Zinc-Coated (Galvanized) by the Hot-Dip Process, Commercial Quality.
- D. ASTM A527 – Sheet Steel, Zinc-Coated (Galvanized) by the Hot-Dip Process, Lock-Forming Quality.
- E. ASTM B209 – Aluminum-Alloy Sheet and Plate.
- F. ASTM B221 – Aluminum-Alloy Extruded Bars, Rods, Wire, Shapes, and Tubes.

1.02 SUBMITTALS

- A. Submit under provisions of Section 01330.
- B. Shop Drawings: Indicate louver layout plan and elevations, opening and clearance dimensions, tolerances; head, jamb and sill details; blade configuration, screens, blankout areas required, and frames.
- C. Product Data: Provide data describing design characteristics, maximum recommended air velocity, design free area, materials and finishes.
- D. Samples: Submit samples illustrating finish and color of exterior and interior surfaces.
- E. Manufacturer's Certificate: Certify that products meet or exceed specified requirements.

1.03 OPERATION AND MAINTENANCE DATA

- A. Submit under provisions of Section 01700.
- B. Maintenance Data: Include lubrication schedules and adjustment requirements.

1.04 QUALIFICATIONS

- A. Manufacturer: Company specializing in manufacturing products specified in this Section with minimum three (3) years documented experience.

1.05 COORDINATION

- A. Coordinate the Work with wall construction.
- B. Coordinate the Work with installation of mechanical ductwork.

1.06 COLORS

- A. Colors are specified in Colors/Materials Schedule.

1.07 ALTERNATES

See Section 01230 for bidding alternates affecting the Work of this Section.

1.08 SUSTAINABLE BUILDING REQUIREMENTS

See Section 01011 for sustainable building requirements affecting the Work of this Section.

PART 2 – PRODUCTS

2.01 METAL WALL LOUVERS

- A. C/S Group, Model 4177, single drain; sizes as shown on drawings. Fixed louver fabricated from 0.081 inch thick aluminum extrusions, 4 inch depth with insect screen on interior face. 4 feet x 4 feet louver shall have the following performance.
 - 1. 8.02 sf free area.
 - 2. Point of zero water penetration – 1165 FPM.

3. Air flow: 9343 CFM.
4. Maximum pressure drop: 0.25 in H₂O.

2.02 **FASTENERS**

- A. Stainless steel anchor bolts, size and spacing as recommended by louver manufacturer to suit condition.

2.03 **FLASHINGS**

- A. 0.032 inch aluminum sheet, shape as shown on drawings; finish to match louvers.

2.04 **FINISHES**

- A. Painted Finish: Provide Kynar 500 Custom Color Coating on all louver surfaces. Coating shall be applied under controlled conditions at factory or custom paint shop in manner recommended by paint manufacturer.

PART 3 – EXECUTION

3.01 **EXAMINATION**

- A. Verify that prepared openings and flashings are ready to receive work and opening dimensions are as indicated on shop drawings.
- B. Verify that electric power is available and of the correct characteristics.

3.02 **INSTALLATION**

- A. Install louver assembly in accordance with manufacturer's instructions.
- B. Install louvers level and plumb.
- C. Install flashings and align louver assembly to ensure moisture shed from flashings and diversion of moisture to exterior.
- D. Secure louvers in opening framing with concealed fasteners.
- E. Install perimeter sealant and backing rod in accordance with Section 07900.

3.03 **ADJUSTING**

- A. Adjust work under provisions of Section 01700.
- B. Adjust operable louvers for freedom of movement of control mechanism.
Lubricate operating joints.

3.04 **CLEANING**

- A. Clean work under provisions of 01700.
- B. Strip protective finish coverings.
- C. Clean surfaces and components.

END OF SECTION

SECTION 10441

SIGNAGE

PART 1 – GENERAL

1.01 POLICIES

- A. All signs located on Pacific Lutheran University property must be in compliance with the Policies and Specifications outlines in the Pacific Lutheran University Signage Program Project Manual. Further, all such signs must conform to existing zoning and sign ordinances. Therefore, all signs located on Pacific Lutheran University property must be coordinated and ordered through Construction Management.

1.02 REFERENCES

- A. A reference copy of the Pacific Lutheran University Signage Program Project Manual is available to designers or any other interested persons by contacting Construction Management. In addition to policies, specifications, drawings, and purchasing information, the manual contains copies of the sign ordinances from the local municipalities having regulatory authority for exterior signs on the campus.
- B. ANSI A117.1 – Specifications for Making Buildings and Facilities Accessible To and Usable By Physically Handicapped People.

1.03 SUBMITTALS

- A. Submit under provisions of Section 01330.
- B. Shop Drawings: Indicate sign styles, lettering font, foreground and background colors, locations, overall dimensions of each sign.
- C. Samples: Submit sample signs, illustrating type, style, letter font, and colors specified; method of attachment.
- D. Manufacturer's Installation Instructions: Include installation template and attachment devices.

1.04 **QUALIFICATIONS**

- A. Manufacturer: Company specializing in manufacturing the Products specified in this Section with minimum three (3) years documented experience.

1.05 **REGULATORY REQUIREMENTS**

- A. Install in conformance with Title III of the Americans and Disabilities Act, Public Law 101-336 and Washington State Rules and Regulations for Barrier Free Design, WAC 51-20.

1.06 **DELIVERY, STORAGE, AND HANDLING**

- A. Deliver, store, protect, and handle products to site under provisions of Section 01600.
- B. Package signs, labeled in name groups.

1.07 **ALTERNATES**

See Section 01230 for bidding alternates affecting the Work of this Section.

1.08 **COLORS**

- A. Colors are specified in Colors/Materials Schedule.

1.09 **SUSTAINABLE BUILDING REQUIREMENTS**

See Section 01011 for sustainable building requirements affecting the Work of this Section.

PART 2 – PRODUCTS

2.01 **MANUFACTURERS**

- A. Apco/Northwest, Graphic Systems, Inc.
- B. Inland Pacific
- C. Substitutions under provisions of Section 01600.

2.02 EXTERIOR SIGNAGE

A. General

1. PLU SIGNAGE PLAN

2. Exterior Campus Signage includes:

- a. Freestanding Aluminum Signs
- b. Buildings Mounted Aluminum Frame and Panel Signs
- c. Street Signs
- d. Cast Aluminum Letters/Numbers mounted to building facades

B. Policies

1. All signs located on Pacific Lutheran University property must be in compliance with the Policies and Specifications outlined in the Pacific Lutheran University Signage Program Project Manual. Further, all such signs must conform to existing zoning and sign ordinances. Therefore, all signs located on Pacific Lutheran University property must be coordinated and ordered through Construction Management.

C. Reference

1. A reference copy of the Pacific Lutheran University Program Project Manual is available to designers or any other interested persons by contacting Construction Management. In addition to policies, specifications, drawings, and purchasing information, the manual contains copies of the sign ordinances from the local municipalities having regulatory authority for exterior signs on the campus.

D. Building Identification Sign; Building Name and Address:

1. Building name and address consist of cast aluminum dimensional text. Text is flush mounted to face of brick building.
2. Dimensional Text (Letters/Numbers):
 - a. Material: Brushed anodized aluminum text, pin mounted.

- b. Finish: Brushed anodized aluminum.
- c. Letter Thickness: ½ inch minimum.
- d. Text and Size: Arial 48
 - 1) “12501” & “54” – 8 inch high numbers.
- e. Text Style: Arial.
- f. Type Code: All letters uppercase text.
- g. Mounting: Pin mount; conceal fasteners. Letters to be mounted onto metal panel system.
- h. Location: Refer to sheet A301, detail 10A & 10E.

E. Handicap Accessible Parking Signs

- 1. Handicap accessible parking sign with “Van Accessible” and “State Disabled Parking Permit Required” messages.
- 2. Location: At handicap parking stall.
- 3. Manufacturer: Zumar Industries, Inc. (800) 426 –7967.
 - a. Model Number: Washington State Regulatory Sign #R7-801.
Note: Include “Van Accessible” notation.
- 4. Installation: Posts are 2-3/8 inch O.D. galvanized steel with exposed end capped. Attachment bolts and nuts to be preened to deter removal.

2.03 INTERIOR SIGNAGE

A. General

- 1. The Pacific Lutheran University Interior Sign Standard has been developed to address the need for functional, flexible and serviceable interior signs. The intent of this standard is to ensure the consistency and visual effectiveness of the signs while allowing the signage design to complement the architectural design of the building.
- 2. These standards shall be used as a reference and adhered to when designing, ordering, and installing permanent interior signs in Pacific

Lutheran University buildings. Custom signage is allowed only with the approval of the Facilities Management Department.

3. All interior signage in campus buildings must conform to the requirements of the American National Standards Institute (ANSI). For the purposes of this Standard, all references to “ADA compliance” shall include compliance with ICC/ANSI A117.1-1998 and compliance with the ADA Accessibility Guidelines (ADAAG). References to these standards can be found within this document.
4. Signs located on Pacific Lutheran University property should be reviewed and/or coordinated through Construction Management. Basic standardized formats and templates (hard copy and electronic) for changeable interior signs are available from Construction Management.
5. Hazard signs (such as radiation, electrical hazard, poisonous gases, etc.) and Emergency Egress Signage are specifically excluded from provisions of this standard and shall be provided for and maintained under terms of applicable code, regulation, ordinance, or other governing authority, see below.

B. Sign Uses

1. Sign usage for Interior signs include the following broad category divisions:
 - a. Way-finding Signage
 - b. Identification Signage
 - c. Temporary Signage
 - d. Recognition Signage
 - e. Hazard Signage
 - f. Emergency Egress Signage
2. Way-finding Signage: Used to direct people to the intended destination. May be wall or ceiling mounted. Must be tactile when it applies to ADA compliant signage, but, otherwise, may be subsurface (back applied on clear acrylic) or changeable (exception for hanging signs). Types: Directories, Area signs, Directional Signs and Floor Plans

- a. Directories: Directories shall be a changeable type, centrally located at main entries or other points of decision in the building (e.g. across from elevators). Wherever possible, directories should list departments as well as alphabetical occupant names.

Sign Size: Varies with application

Content: Departments, Occupants

Text: Arial

Text Size: Maximum – 1 1/2", Minimum – 5/8"

- b. Area Signs: Area Signs shall be Tactile or Subsurface and identify discrete areas within a building. Signs should be located only at key points within circulation areas. No Area Signs within occupied spaces.

Sign Size: 12" x 12" or less

Content: Departments, Areas

Text: Arial

Text Size: Maximum – 1 1/2", Minimum – 5/8"

- c. Directional Signs and Floor Plans: Directional Signs shall be Tactile or Subsurface and identify discrete areas within a building. Signs should be located only at key points in the building (e.g. corridor intersections, stairs, etc.)

Sign Size: 12" x 12" or less

Content: Departments, arrows, room numbers

Text: Arial

Text Size: Maximum – 1 1/2", Minimum – 5/8"

3. Identification Signage: Identification Signage shall indicate the following:

- a. For room identification, in ALL cases have the room number;
- b. In appropriate cases, department, use, or space inventory room name;
- c. In desirable cases, the occupant and related information.
- d. In pictogram/symbolic case, shall comply with ICC/ANSI A117.1-1998 Sec. 703.6.

- e. All rooms whose function is permanent shall have ADA compliant tactile signs including tactile letters and Grade II Braille, transcribing all numbers and text. Types: Room number signs, Office signs, Individual name signs, Department Signs, Symbolic Signs, Plaques, and Official Notices.
- 4. Temporary Signage: Temporary Signage may be used in a variety of ways for several purposes including event notification, temporary hazard signs, instructional signs, as well as others. Political or personal signs are not allowed on Campus.
- 5. Hazard Signage: Hazard Signage is NOT covered under this standard. Please refer to the Building Code.
- 6. Emergency Egress Signage: Emergency Egress Signage is NOT covered under this standard. Please refer to the Building Code.

C. Interior Signage Types

- 1. Interior Signage Types consist of one of the following:
 - a. Tactile, fixed message.
 - b. Subsurface, non-changeable.
 - c. Changeable.
 - d. Temporary.
- 2. Tactile and Braille: Both Braille and tactile text signs shall be provided where tactile signs are required. Braille and tactile text signs shall be provided for elevators, stairways, floor level designation, telephones, toilet rooms, and all permanent occupancy/use spaces, i.e. lecture rooms, auditoriums, theaters, cafeterias, dining halls, etc.
- 3. Subsurface, non-changeable: Subsurface, non-changeable signage may be used anywhere tactile signage is not specifically required by law.
- 4. Changeable Signs
 - a. Changeable signage is strongly encouraged for any room or area that; a) does not specifically require tactile signage, or b) in addition to the tactile signage.
 - b. Color schemes are to be selected by a design professional.

- c. Installation and mounting shall be done wherever possible with double stick foam tape and as specified.

5. Temporary Signs:

- a. General – Temporary signs adhered, tacked, nailed, screwed or otherwise fastened to painted walls or surfaces subject to damage are not allowed. Signage or posting of a temporary nature shall be restricted to bulletin boards or like locations. Where temporary Signage is required by law or ordinance for Construction, or similar temporary projects, the Project shall pay to have the surfaces affected by the removals of temporary signs repaired or restored.
- b. Banners used for symbolic or text messages shall be temporary in nature. With the exceptions of architectural banners, banners associated with exhibitions of limited duration and athletic award display, all transient banners shall be restricted to a thirty day period of display. Banners shall be of appropriate size, material, construction, and displayed in a manner to pose no fire or safety risks.
- c. Bulletin Boards shall not be placed in a manner to interfere with or block signage. Bulletin boards in corridors shall have a suitable frame and be constructed of a fire-rated or retardant material.

6. Sign Layout, Message and Text

- a. To the greatest extent possible, signs shall be clear, flexible and efficient in their message. The number of words shall be kept to a minimum, using key phrases only.
- b. Messages shall be left justified when arrows occur on the signs.
- c. Use of the Pacific Lutheran University seal is permitted in the message layout of signs for departmental or larger campus units. See Construction Management
- d. Signs of Uniform size are encouraged for similar functions regardless of the brevity of one message over another. The suggestion is to size the sign for all rooms in a given area to fit the largest layout and then hold that size throughout.

D. Execution

1. Installations shall conform to the following provisions.
 - a. Signs will be located in a logical and consistent manner to maximize their effectiveness, and minimize their quantity.
 - b. Signs associated with individual rooms will be placed on the wall on the latch side of the door and 4" from the door trim, and 5'-0" (60") from the floor to the center of the sign, or group of signs.
 - c. Restroom/Toilet room signs will include the international symbols with appropriate copy and will be centered on the door 5'-0" (60") from the floor to the bottom edge of the sign. Tactile text, raised pictograms, and Braille shall be provided at restroom locations.
 - d. Individual name signs may be mounted by double adhesive foam tape (preferred) and clip on brackets. The most appropriate method should be used recognizing the advantages and disadvantages of each method.
 - e. Wherever possible, signs will be mounted with double face tape and silicone adhesive. If conditions do not allow for attaching the signs with tape, screws may be used only if the design of the sign allows for them to be concealed.
2. It is the intent of this standard to minimize damage to walls and surfaces caused by the uncontrolled installation of limited duration signs and their subsequent removal or modification. Should a tape-mounted sign need to be relocated, there are very effective means of minimizing the damage to the surface. DO NOT pull the sign off the wall. Contact Construction Management for removal suggestions.

PART 3 – EXECUTION

3.01 **EXAMINATION**

- A. Verify that substrate surfaces are ready to receive work.

3.02 **INSTALLATION**

- A. Install in accordance with manufacturer's instructions.

- B. Install signs after all wall and ceiling surfaces are painted and finished.
- C. Install centered and level, in line and in accordance with manufacturer's instructions. Center line of sign mount 60 inch above finish floor.
- D. Clean and polish in accordance with manufacturer's recommendations.

3.03 PLAQUE SIGNS SCHEDULE: SEE ATTACHED GRAPHIC DETAILS

INSERT DRAWINGS HERE

END OF SECTION



Pacific Lutheran University

Campus Signage Standards Manual

JUNE 1999

Owner
Pacific Lutheran University
Tacoma, Washington

Graphic Design Consultant
Mayer/Reed
319 SW Washington Street
Suite 820
Portland, Oregon 97204
Tel 503.223.5953
Fax 503.223.8076

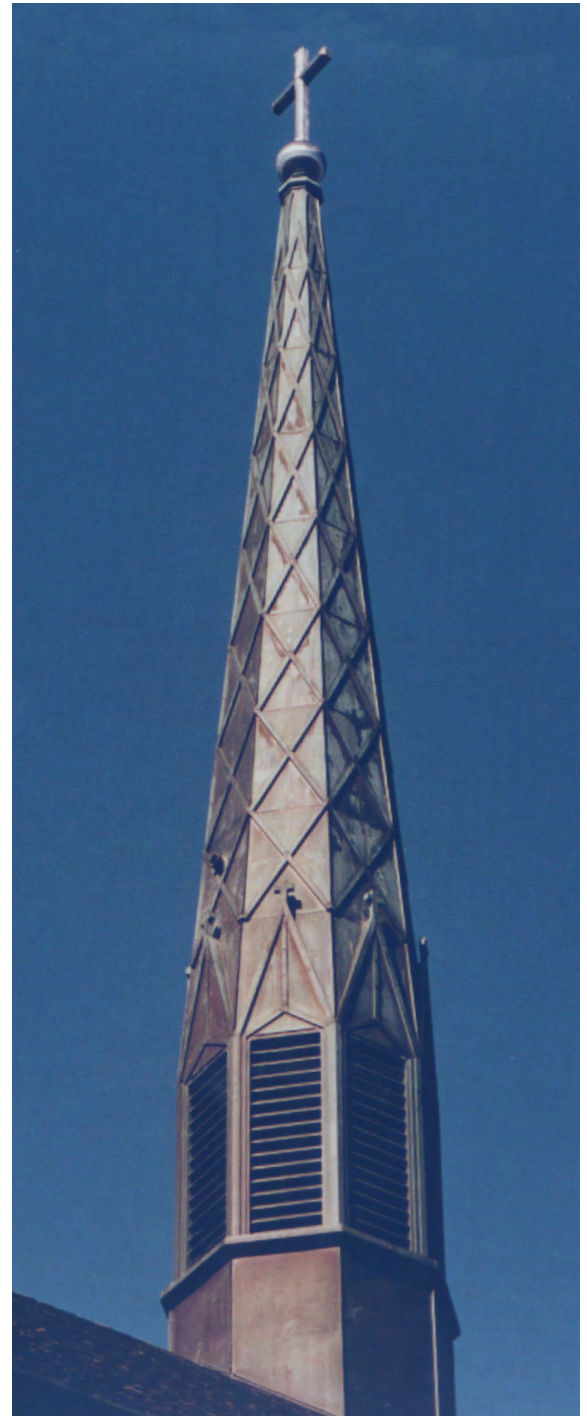

Table of Contents

Concept Overview		1.1 - 1.16
Sign Type Overview		2.1
Sign Type A	PERIMETER CAMPUS IDENTITY SIGN	3.1
Sign Type B	CAMPUS DIRECTORY	4.1 - 4.4
Sign Type C.1	BUILDING I.D. SIGNS WITH DIRECTORY	5.1 - 5.5
Sign Type C.2	RESIDENCE HALL I.D. SIGNS	6.1 - 6.3
Sign Type C.3	ANCILLARY BUILDING I.D. SIGNS	7.1 - 7.3
Sign Type C.4	WALL MOUNTED BUILDING I.D. SIGNS	8.1 - 8.3
Sign Type C.5	BUILDING NUMBERING SIGNS	9.1
Sign Type D	ENTRY DOOR MESSAGES	10.1 - 10.2
Sign Type E	PARKING LOT I.D. SIGNS	11.1 - 11.5
Sign Type F	VEHICULAR WAYFINDING SIGNS	12.1 - 12.3
Sign Type G	PEDESTRIAN WAYFINDING SIGNS	13.1 - 13.3
Sign Type H	PARKING LOT REGULATORY SIGNS	14.1 - 14.3
Typography & Symbols		15.1 - 15.3
Specifications		16.1 - 16.6
Color Samples		17.1

The Campus Signage Plan and accompanying Campus Signage Standards has been undertaken in response to the PLU 2000: Embracing the 21st Century statement of purpose. This plan also reflects the recommendations of the Pacific Lutheran University Framework Master Plan prepared by Zimmer Gunsul Frasca which was approved by the Board of Regents on January 25, 1997.

Where the campus master planning effort directs the maintenance, improvement and development of the physical environment. The Campus Signage Plan supports the physical environment of the university by establishing an appropriate academic image which defines the campus perimeter and entries; provides information on access to campus facilities and activities for students, staff and visitors; and unifies the campus through uniform building signage that incorporates identification of academic and administrative functions. The Plan improves visitor access to the campus through improvements to wayfinding and parking; and unifies the upper and lower campus areas through improvements along the wooded hillside pedestrian paths. Visitors and guests of the university are welcomed by new perimeter identity gateways and improved access to information kiosks, visitor and event parking.

Campus signage is a vital element in the development of the campus's physical character. The goals of this program include creating welcoming entries to the campus, clearly directing students and visitors around the campus, and reinforcing the image of the university, by conveying permanence and stability through quality of design. To achieve these goals the signage must create a solution unique to Pacific Lutheran University. The signage program was developed by drawing upon the rich forces of history which have shaped the campus environment. These forces include the Scandinavian heritage and aesthetic; the ideal of the Lutheran principles of integrity, simplicity and servitude; and the architectural character of the historic structures.

The university's identity and campus signage is a vital element in the con-



The character of the signage program reflects both contemporary and historic Scandinavian design influences.



Native random laid stone introduced at the campus perimeter identity signs will connect campus signage to the earth and park-like setting.

tinuing refinement of the physical character of the campus and its academic environment. New design standards have been created for a family of exterior signage elements. These signage elements are presented in detail and include the following:

- Perimeter Campus Identity
- Campus Directory Kiosks
- Building Identity
- Building Entry Door Messages
- Parking Lot Identity Signs
- Vehicular Wayfinding Signs
- Pedestrian Wayfinding Signs
- Parking Lot Regulatory Signs

Historic and environmental influences are evident in the simple, essential character of the proposed signage. Quality materials, subtly detailed reflect the character of the ribbed steeple at Eastvold Chapel and respond to both historic and contemporary Scandinavian influences. The color system is drawn from the deep, rich red earth tones found in many of the brick buildings, the cor-ten steel sculpture located in Red Square and the roof of Xavier Hall. As the signage plan is implemented it's complementary color to the forest green backdrop of the campus park-like setting will become apparent.

Effective implementation of the Signage Plan will be enhanced by progress on both the campus landscape master plan and campus lighting plan. During our field visits to the campus, it was apparent that improvements to the careful placement of signs in landscaped areas will enhance the park-like setting of the campus and elevate the perception of quality and care. Likewise, improvements to the campus lighting plan will enhance the welcoming character at entries and at the campus directory kiosks.

Perimeter Campus Identity Signs

The Campus Identity signs are the most hierarchically significant signs of those presented herein. These signs should embody the Lutheran principles of simplicity and integrity through design and detail. They should represent University ideology by using permanent materials such as concrete, brick and stone. Landscaping should be developed to provide a background setting that creates a place for each of these signs and promotes the park-like character of the campus. Illumination should be incorporated into the site design at these entry points.

Four perimeter sites have been identified for these signs which support the recommendations of the framework mater plan. In addition to these four signs, a Campus Identification Sign should be located at the Garfield Street main campus entry near Harstad Hall. The sign at this location is considered the most important, and is expected to be designed as part of site improvements to that area.

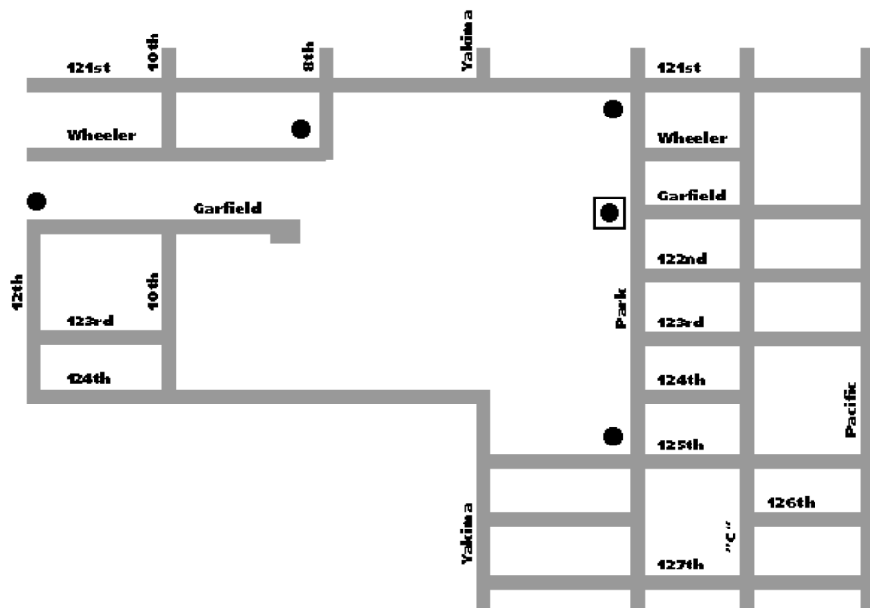

Legend

- ◻● Proposed Main Campus Entry Improvement Area
- Proposed Perimeter Campus Identity

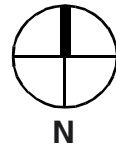

A Perimeter Campus Identity Signs

The illustrations presented here are intended to represent a range of options which convey the potential character and quality of the Campus Identification Signs. Ultimately, these signs may be designed uniformly, or as a family with subtle variations which respond to the particular qualities of each specific site.

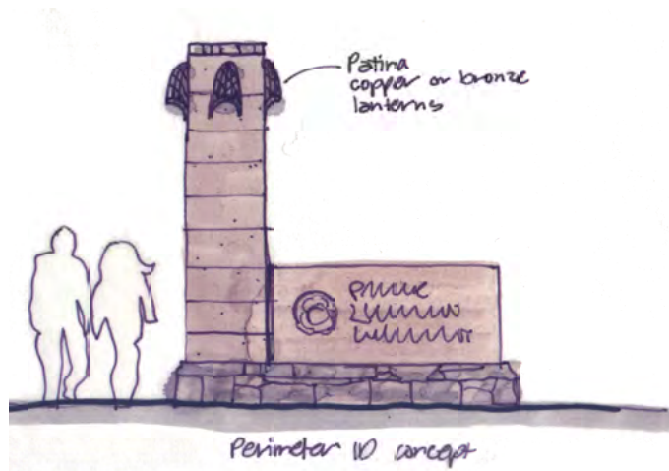

A
Perimeter Campus Identity Signs (cont'd)

Concept A:
 Informal sign structure using random laid stone base with brick or dressed stone column and sign monument.

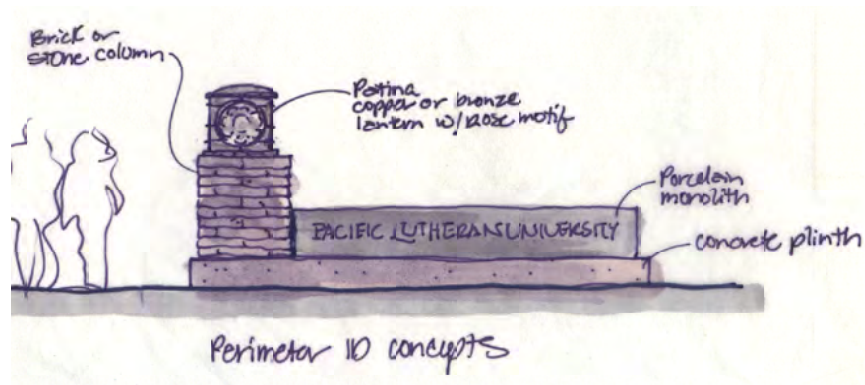
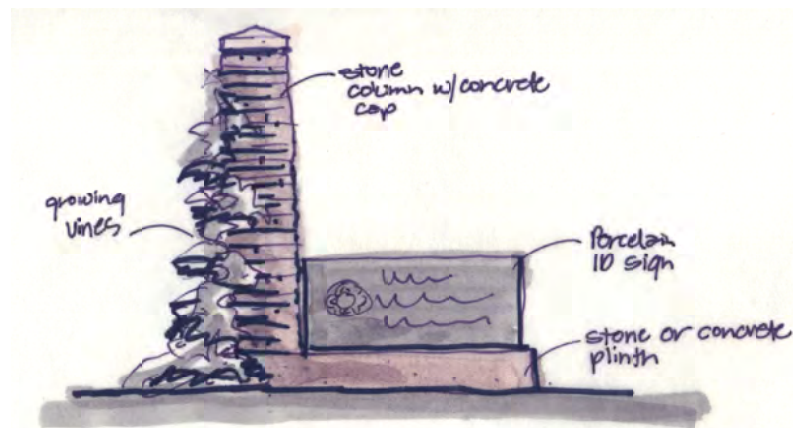
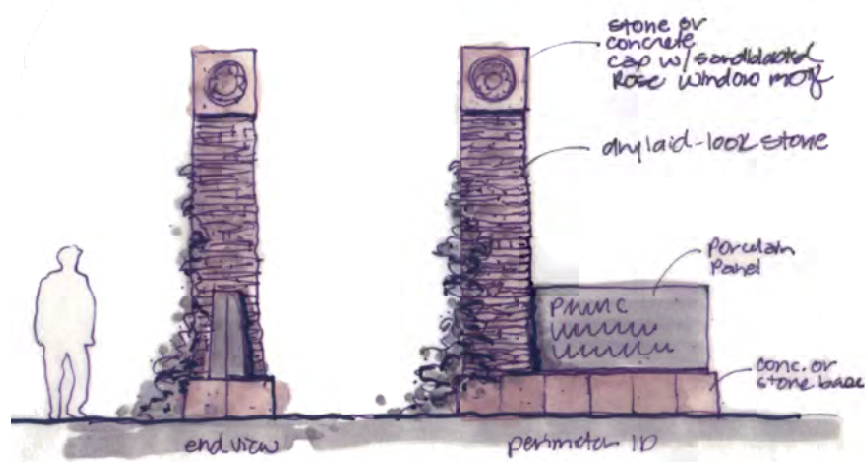

A
Perimeter Campus Identity Signs (cont'd)

Concept B:
 Informal sign structure using random laid native stone.

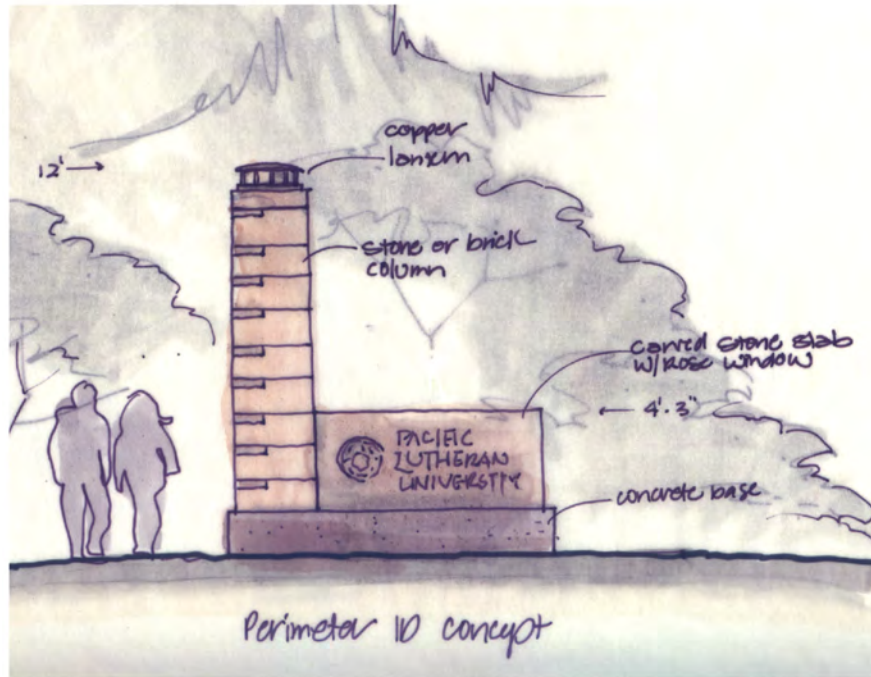

A
Perimeter Campus Identity Signs (cont'd)

Concept C:
Formal sign structure using brick or dressed stone.



Campus Directory

The Campus Directory includes a map of the campus with accompanying directory and printed maps for distribution. New locations should be coordinated with a campus lighting plan.

Pedestrian locations include primary walk-in points such as near Harstad Hall and the Mary Baker Russell Music Center, at public spaces such as Centennial Plaza, and at the top and bottom of the wooded hillside which connects upper and lower campus. This will reinforce visitor orientation between event locations on the upper campus with the lower campus parking areas.

Materials include stone or pre-cast concrete base, painted aluminum directory cabinet with tempered glass door. Map artwork options include screenprinted or color digital imaging.

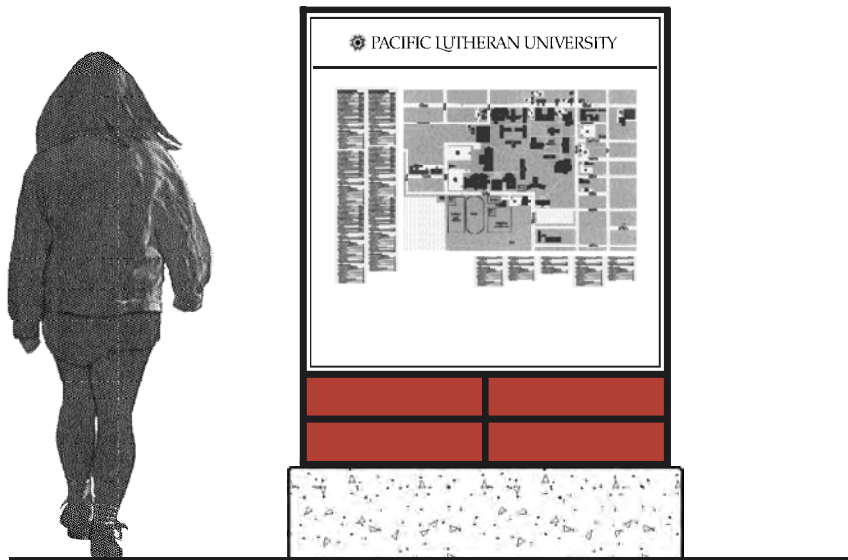

B
Campus Directory

Location strategies include provisions for "drive up" vehicular orientation, as well as pedestrian orientation. Vehicular access locations include visitor parking areas, and should provide either street side pull off area or short term parking space within lot for temporary parking and map retrieval.

B
Campus Directory
(cont'd)

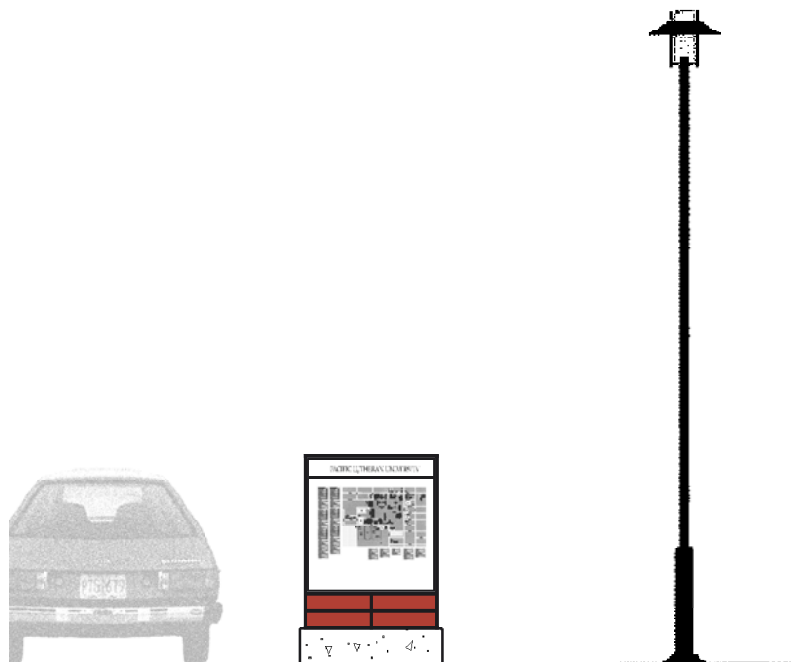
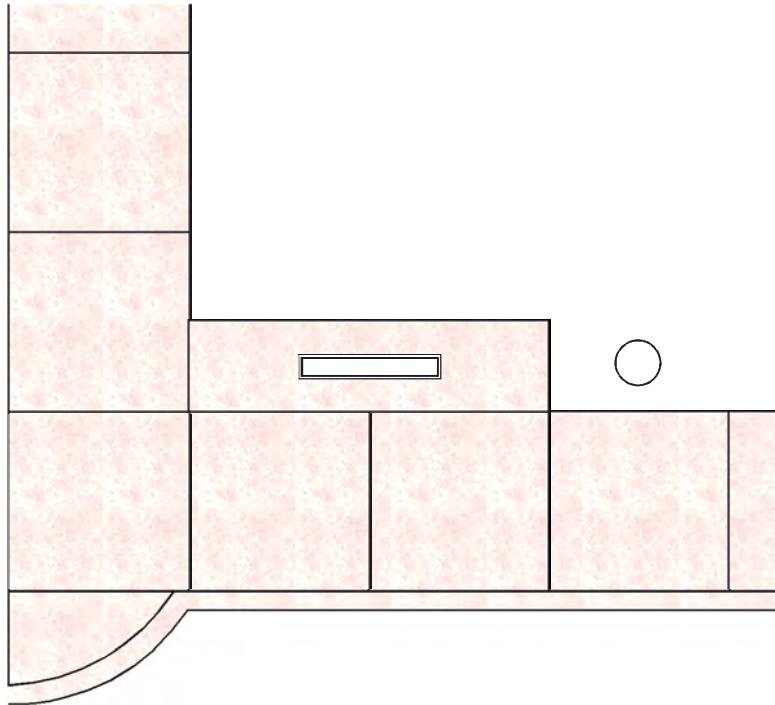

Building Identification Signs

Five types of building identification signs are recommended. They include:

- Building Identification Signs with Directory
- Residential Hall Identification Signs
- Ancillary Building Identification Signs
- Wall Mounted Building Identification Signs
- Building Numbering Signs

Each type of building identification sign has been developed to represent the hierarchy among core academic buildings, residential halls, and ancillary periphery buildings located outside the campus ring road. The design standards also establish methods for identifying secondary entries. Additionally, each design responds to practical considerations regarding visibility.

Freestanding signs should be oriented parallel to the building facade, and should be considered in composition with the building facade and landscape elements.

Materials include painted aluminum and vinyl text. Dimensional metal letters are an option for the building name.

Building ID Signs with Directory

Signs include area for listing major building occupants to reinforce new student and visitor orientation.



C Building I.D. Signs

Residential Hall ID Signs

These signs are primarily located along campus walkways allowing them to be low profile and nestled into the landscape.



Ancillary Building ID Signs

These signs are often located behind street edge shrub plantings and fences requiring a higher profile to achieve visibility from vehicles. Also, the primary building i.d. sign is out of scale with these converted neighborhood houses.

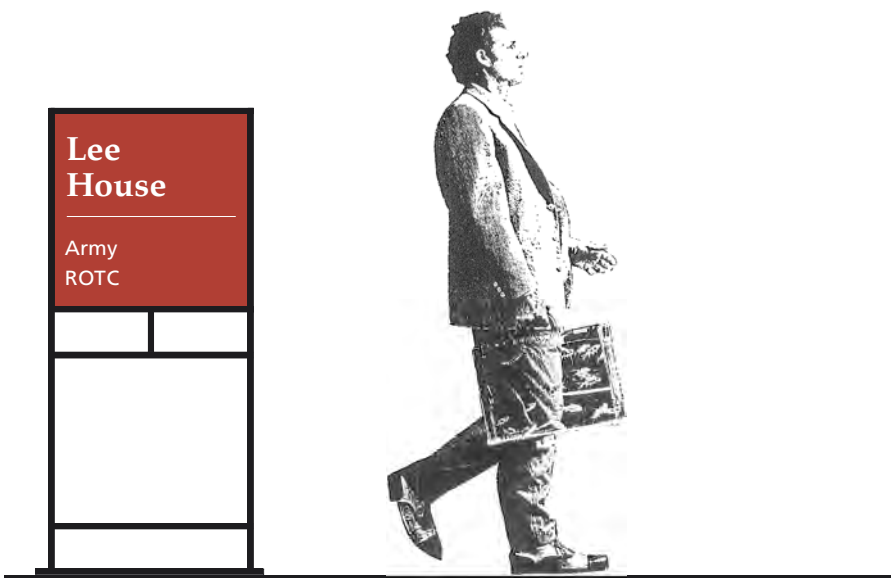

C Building I.D. Signs (cont'd)

Wall Mounted Building ID

This sign may be used at secondary entrances to buildings where a free-standing sign is not desirable, or at ancillary buildings. Consider sign location in composition with building facade.



C
Building I.D. Signs
(cont'd)

Building Numbering Signs

These signs are required per Fire Marshall mandate. Mounting position to be field verified by Fire Marshall.

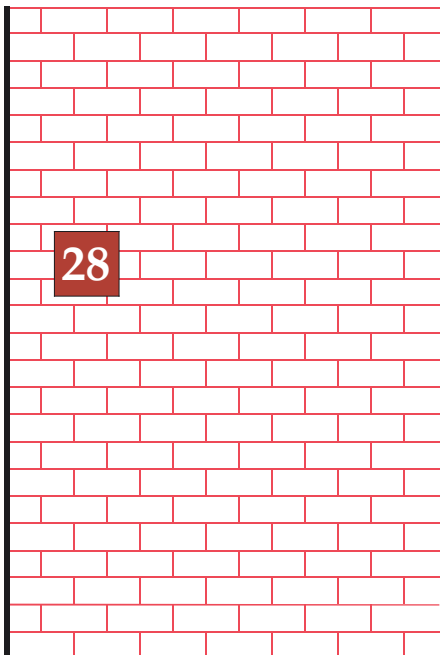

Entry Door Messages

Vinyl letters provide simple, cost effective building identification at secondary building entries. Any restrictions such as "No Smoking", "No Food" may also be handled this way.

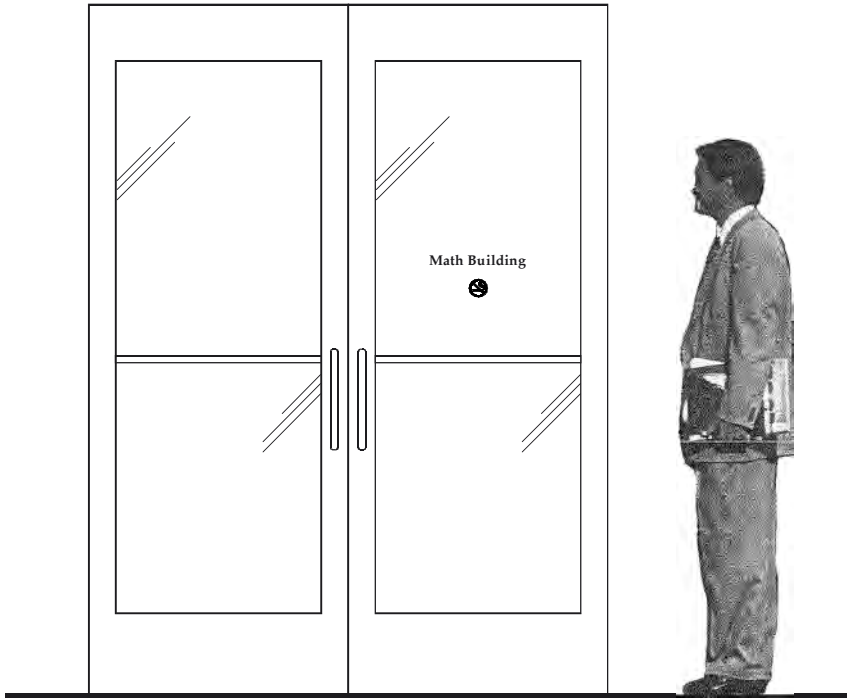

D
Entry Door Messages

Parking Lot ID Signs

Parking Lot Identification signs should clearly designate visitor, student, and staff parking. These signs assist visitor orientation by consistently using the established naming convention where lot names correspond with adjacent destination building names, activity areas such as the "Harstad Lot", or the "University Center Lot".

Visitor orientation and parking options are reinforced by the printed campus maps found at the campus directory kiosk locations.

Locate signs at parking lot entries, parallel or perpendicular to the street to provide optimal visibility. As with other freestanding campus signs, landscaping should provide a setting for these signs. Provide curbs to protect signs.

A comprehensive parking strategy should be developed to simplify sign nomenclature and clearly identify visitor parking for both short term and event use.

Materials include painted aluminum post and panel with reflective vinyl text.

**E
Parking Lot I.D. Signs**

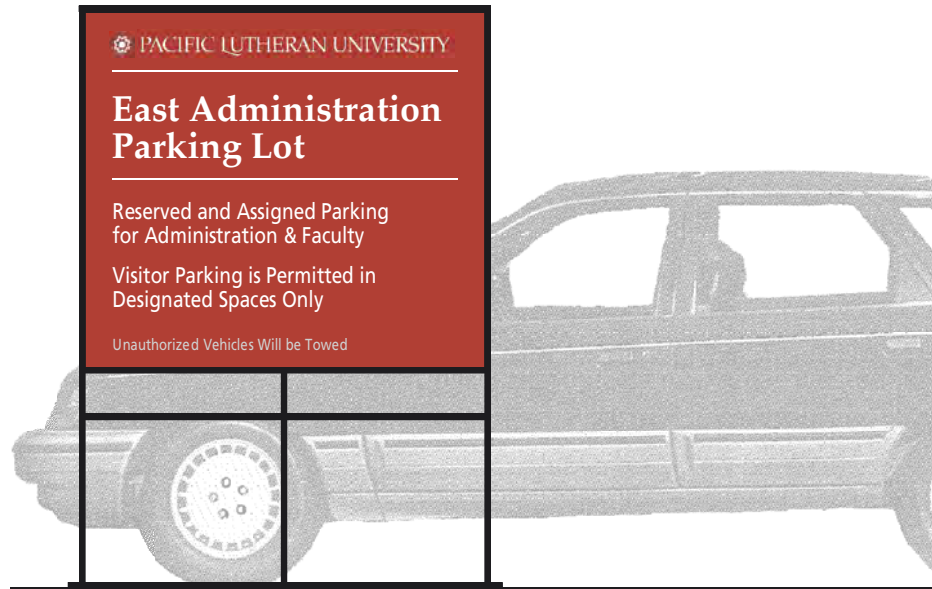

Vehicular Wayfinding

In order to be effective, the Vehicular Wayfinding signs should include a minimal amount of information. The two highest priority elements which should be communicated are "Visitor Info" and "Event Parking". Signs should direct the driver toward the nearest visitor parking area or temporary pull-off area where a Campus Directory Kiosk can be easily accessed. Signs directing visitors toward event parking should direct the driver toward the nearest event-designated parking area.

Signs should be located along the campus ring road, near intersections, in proximity to visitor parking areas, campus information office, or event parking areas. Signs should be sited such that they are visible from a moderate approaching distance.

Materials include painted aluminum post and panel with reflective background and text.

F
Vehicular Wayfinding Signs

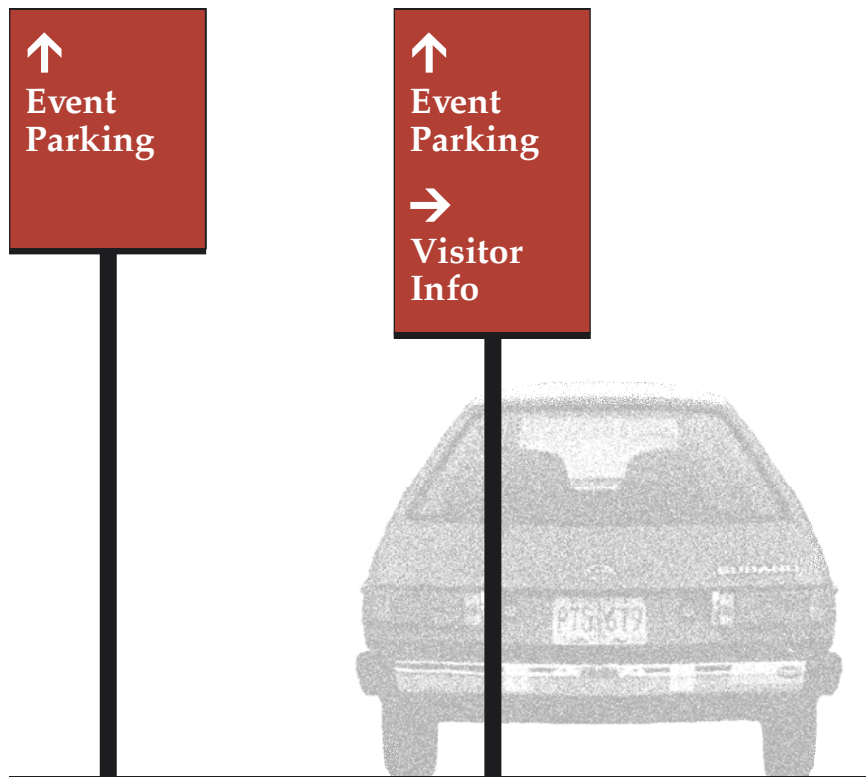

Sign Type F.1

Sign Type F.2

Pedestrian Wayfinding

The Pedestrian Wayfinding signs reinforce visitor orientation for the primary visitor destinations including the Administration Building and the performance halls. It is recommended that these signs also be located at the pedestrian paths which link the upper and lower campus so as to promote campus unification and to direct visitors from the lower campus parking lots to the upper campus event areas.

These signs should be used sparingly to accomplish the described intent. Incorporate signs into landscape improvements such as low stone walls.

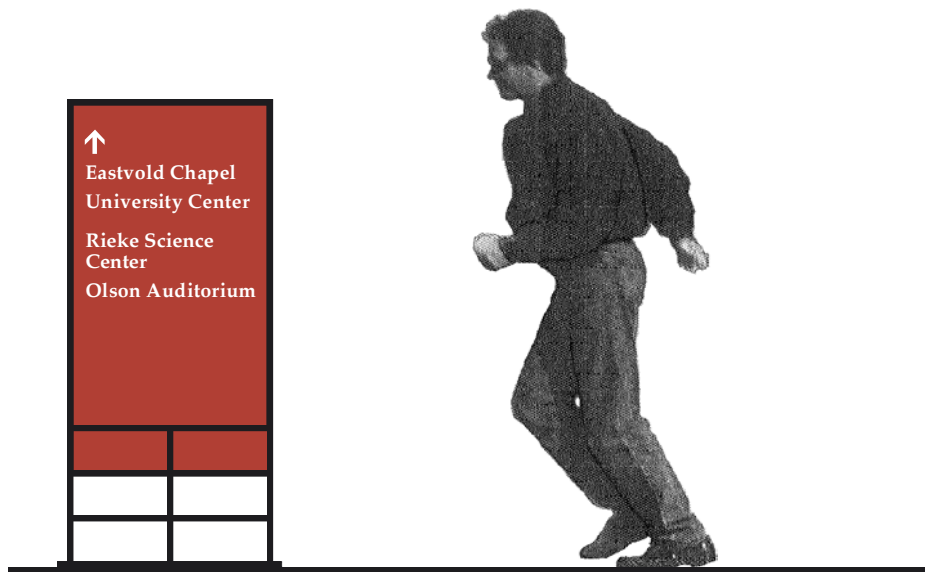

G
Pedestrian Wayfinding Signs

Parking Lot Regulatory Signs

Regulatory signs should be used to identify reserved parking spaces in a consistent manner. They may also be used to designate parking spaces reserved for campus visitors. These signs should be incorporated into an overall parking strategy which will minimize individual parking space signs in the lots. An overall parking strategy or master plan should be developed before any signs are created.

The intent is to provide consistent graphic standards through economical means that minimize sign clutter.

Materials include painted aluminum post and panel with screenprinted or vinyl text.



H
Parking Lot Regulatory Signs

Presented in conceptual form only. See Section 1.

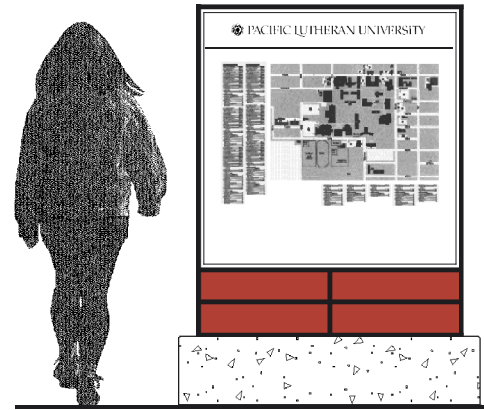

Sign Type B - Campus Directory
See Section 4 for construction details .

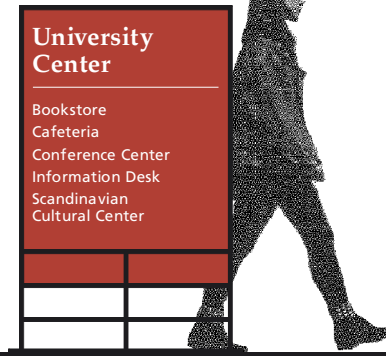

Sign Type C.1 - Building I.D. Signs with Directory
See Section 5 for construction details .

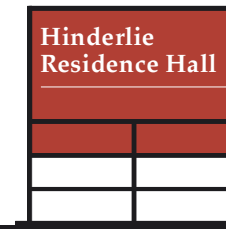

Sign Type C.2 - Residential Hall I.D. Signs
See Section 6 for construction details .

Sign Type A - Perimeter Campus Identity Signs

Refer to Sign Type Overview at left to compare sign type options.

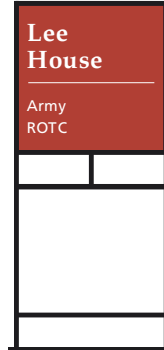

Sign Type C.3 - Ancillary Building I.D. Signs
See Section 7 for construction details .



Sign Type C.4 - Wall Mounted Building I.D. Signs
See Section 8 for construction details .

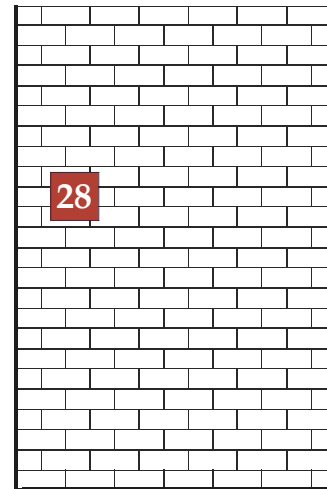

Sign Type C.5 - Building Numbering Signs
See Section 9 for construction details .

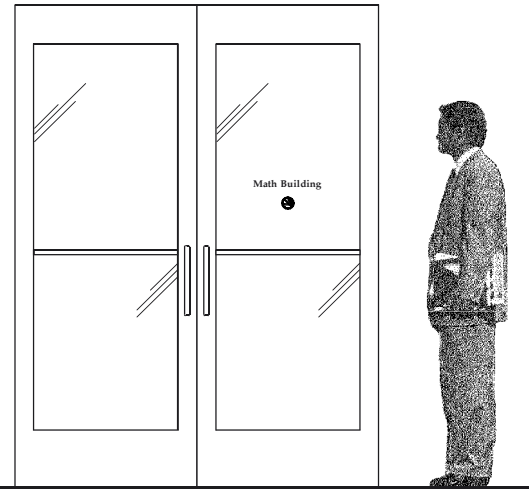

Sign Type D - Entry Door Messages
See Section 10 for construction details .

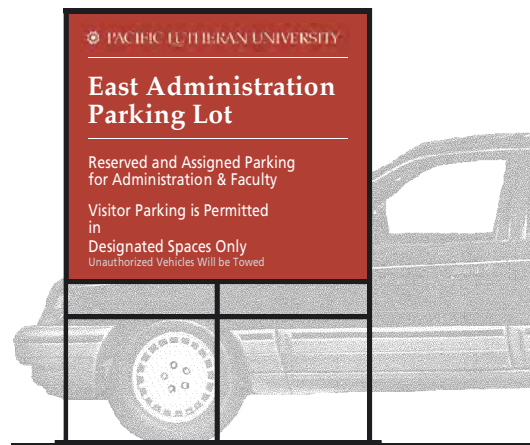

Sign Type E - Parking Lot I.D. Signs
See Section 11 for construction details .

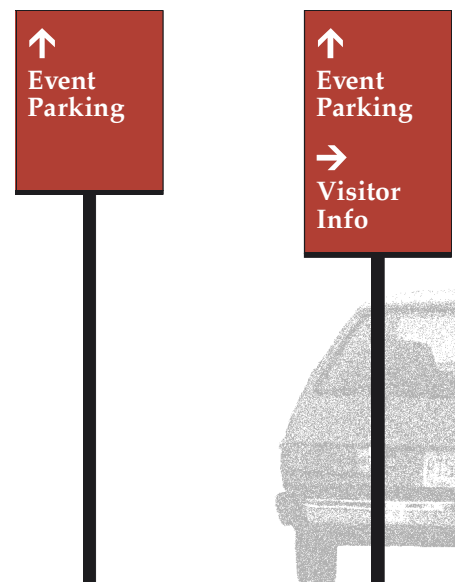

Sign Type F - Vehicular Wayfinding Signs
See Section 12 for construction details .

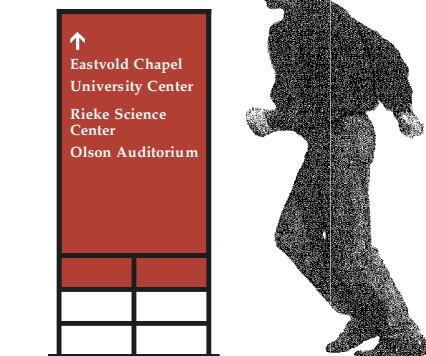

Sign Type G - Pedestrian Wayfinding Signs
See Section 13 for construction details .



Sign Type H - Parking Lot Regulatory Signs
See Section 14 for construction details .

This sign type was presented in conceptual form only which explored scenarios for site specific gateway designs at the campus perimeter. These proposed gateway projects include stone (or masonry) walls and columns, sign monuments with dimensional or inscribed lettering, lanterns and/or sign illumination, and site work. Site work may include grading, planting and irrigation.

Typographic elements of the sign program should be incorporated into these gateways.

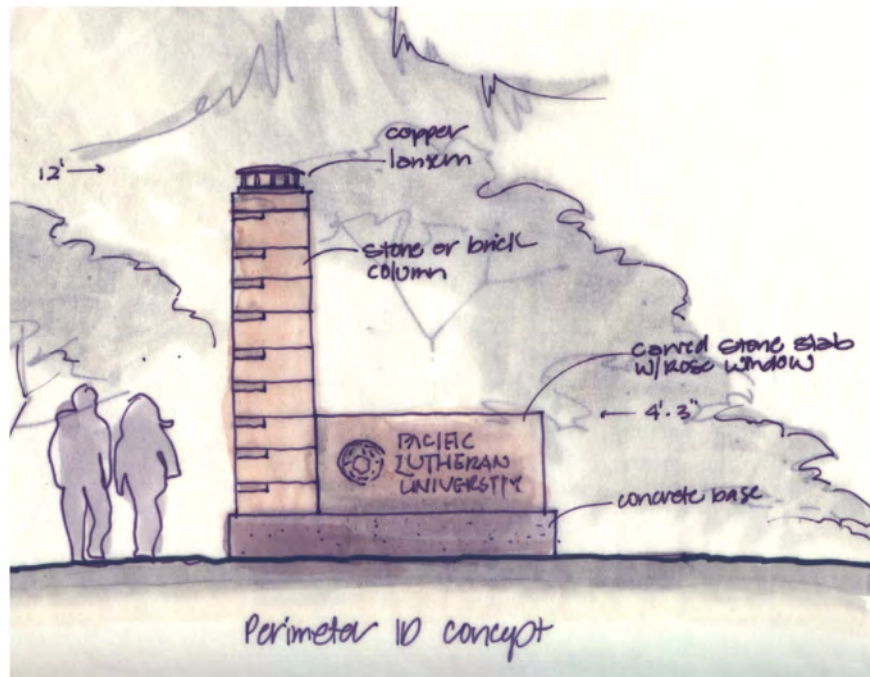

A Perimeter Campus Identity Signs

Construction drawings are not included in this package.

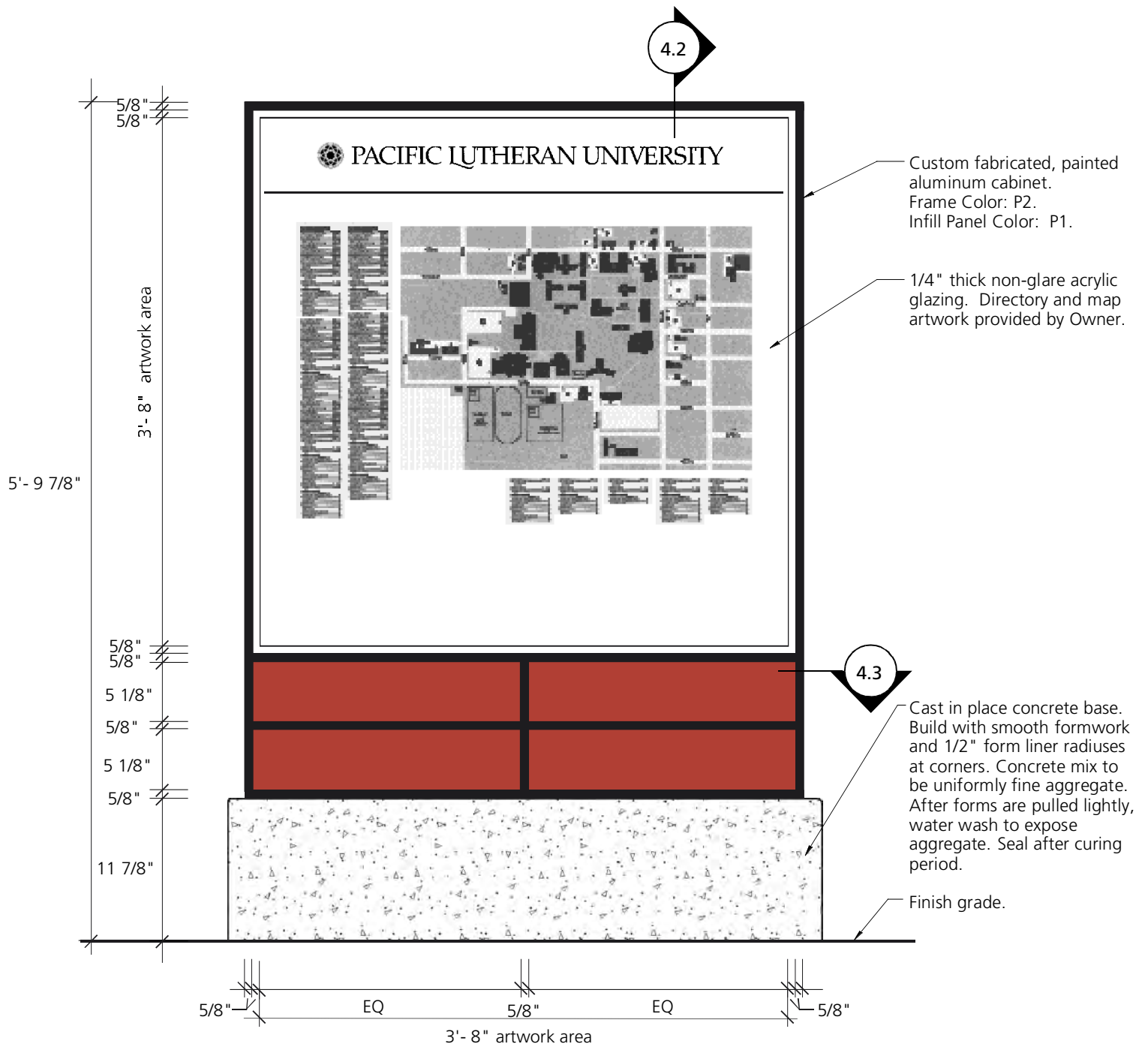

Elevation - Sign Type B

Scale: 1" = 1'-0"

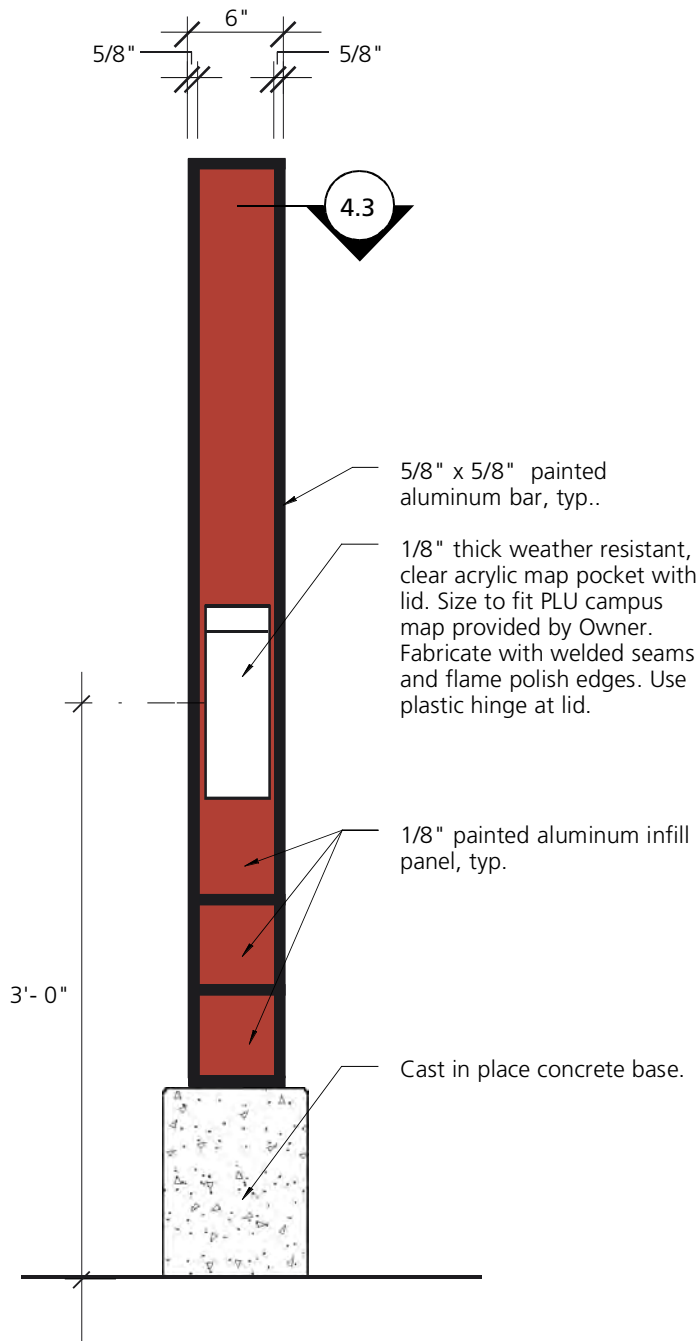

Side View - Sign Type B

Scale: 1" = 1'- 0"

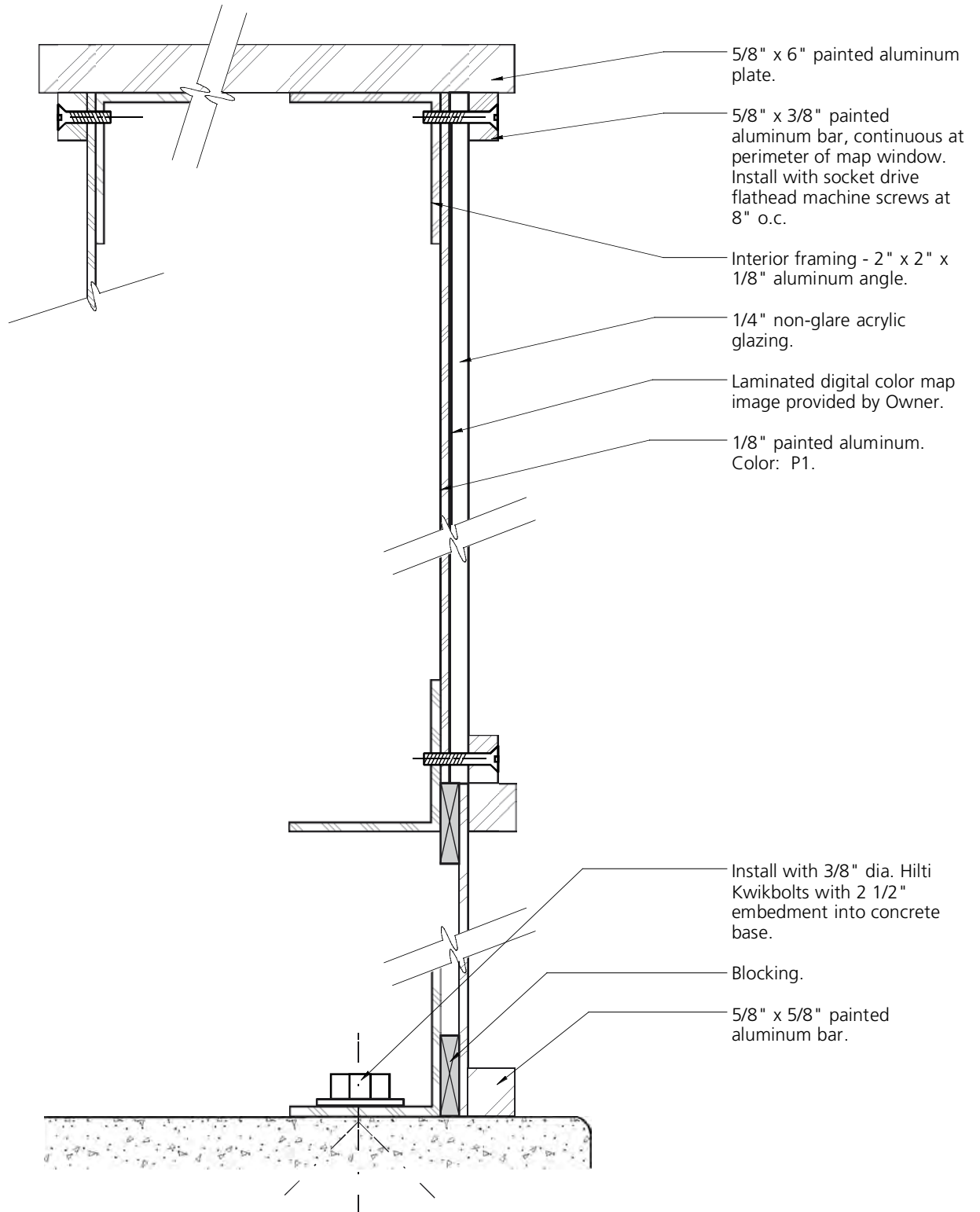

Detail - Sign Type B

Scale: Half Full

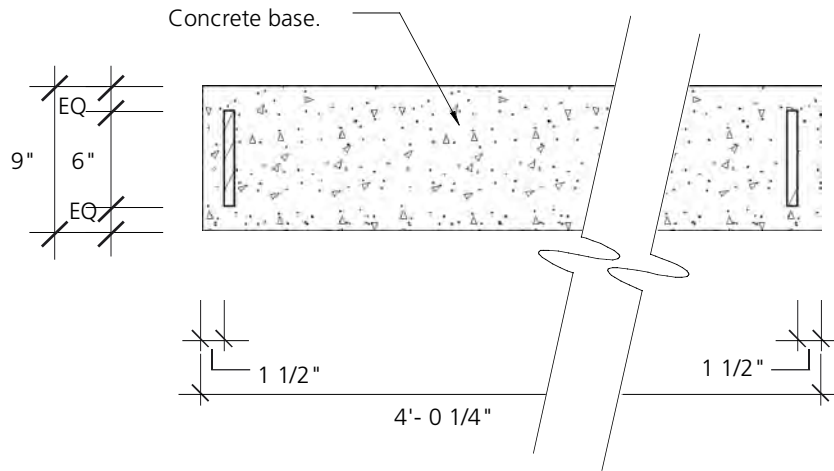

Plan - Sign Type B
Scale: 1" = 1'-0"

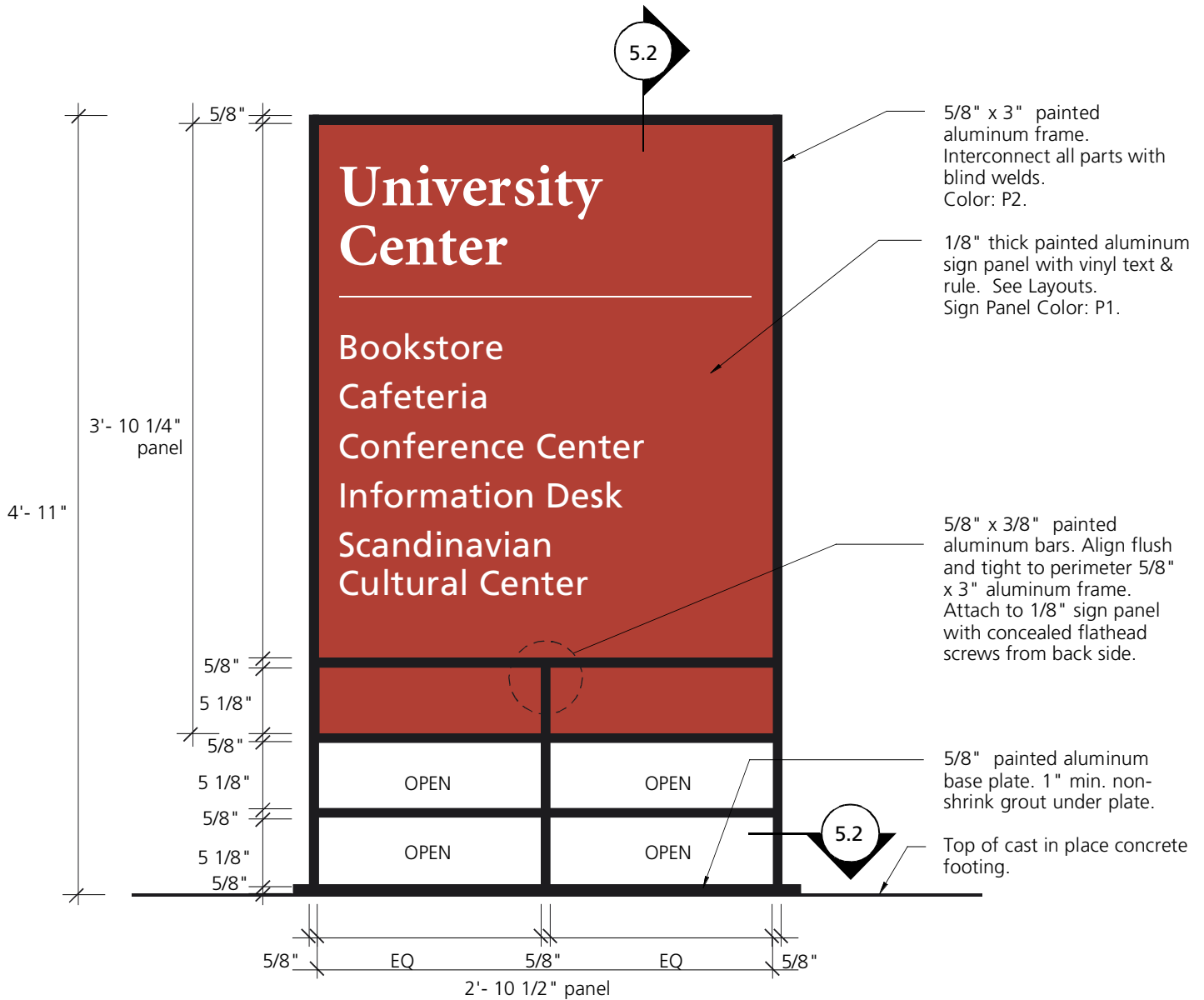

Elevation - Sign Type C.1

Scale: 1" = 1'-0"

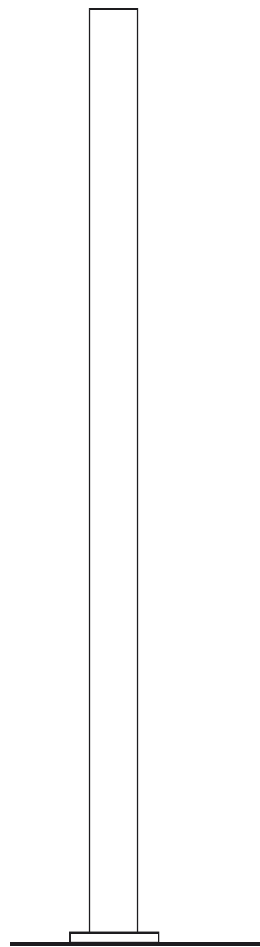

Side View - Sign Type C.1

Scale: 1" = 1'-0"

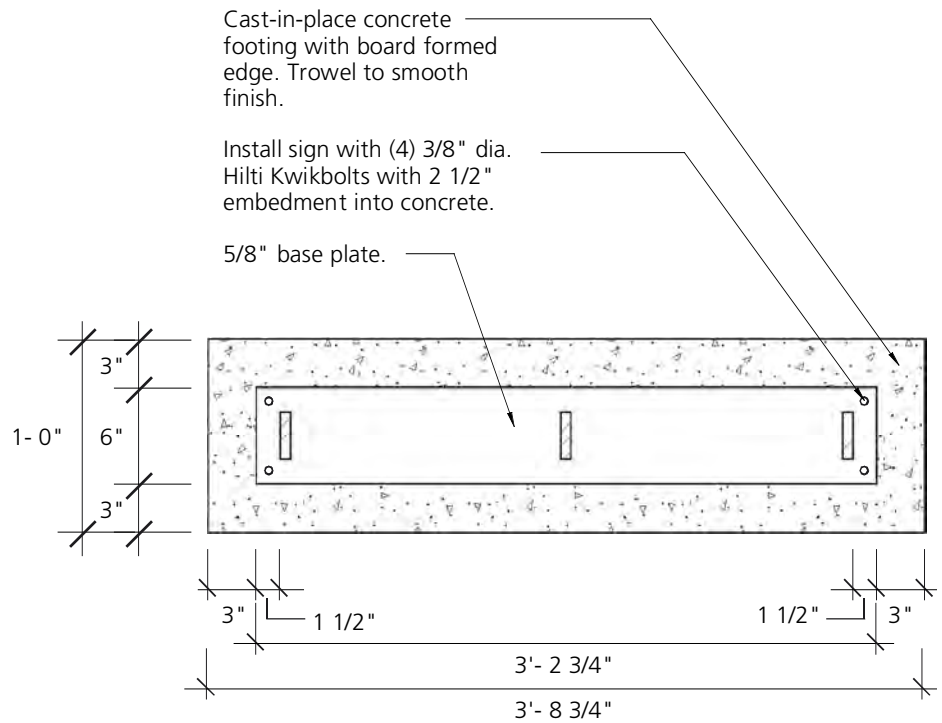

Plan - Sign Type C.1

Scale: 1" = 1'-0"

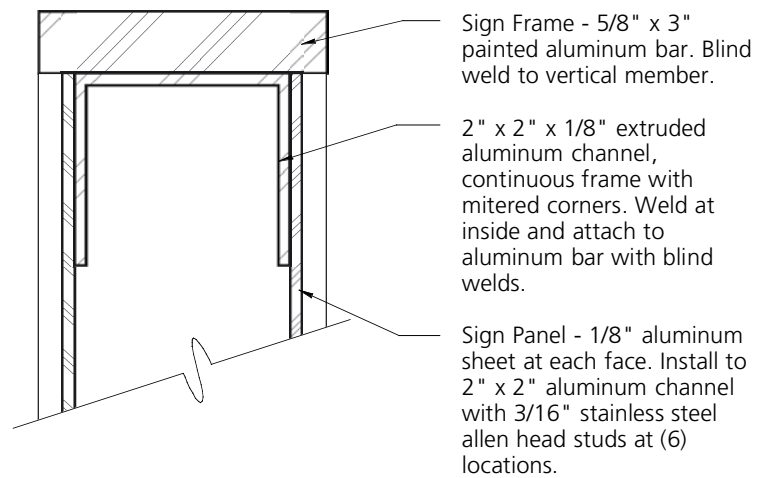

Detail at Top - Sign Type C.1

Scale: Half Full

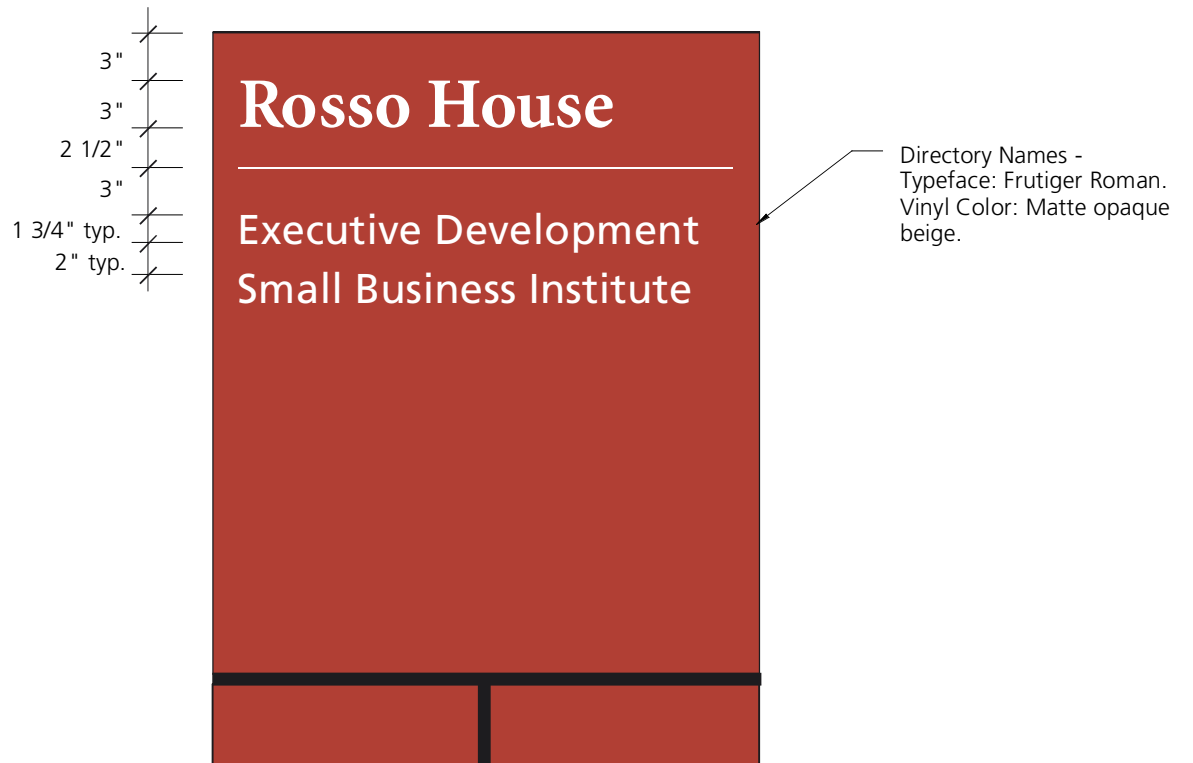
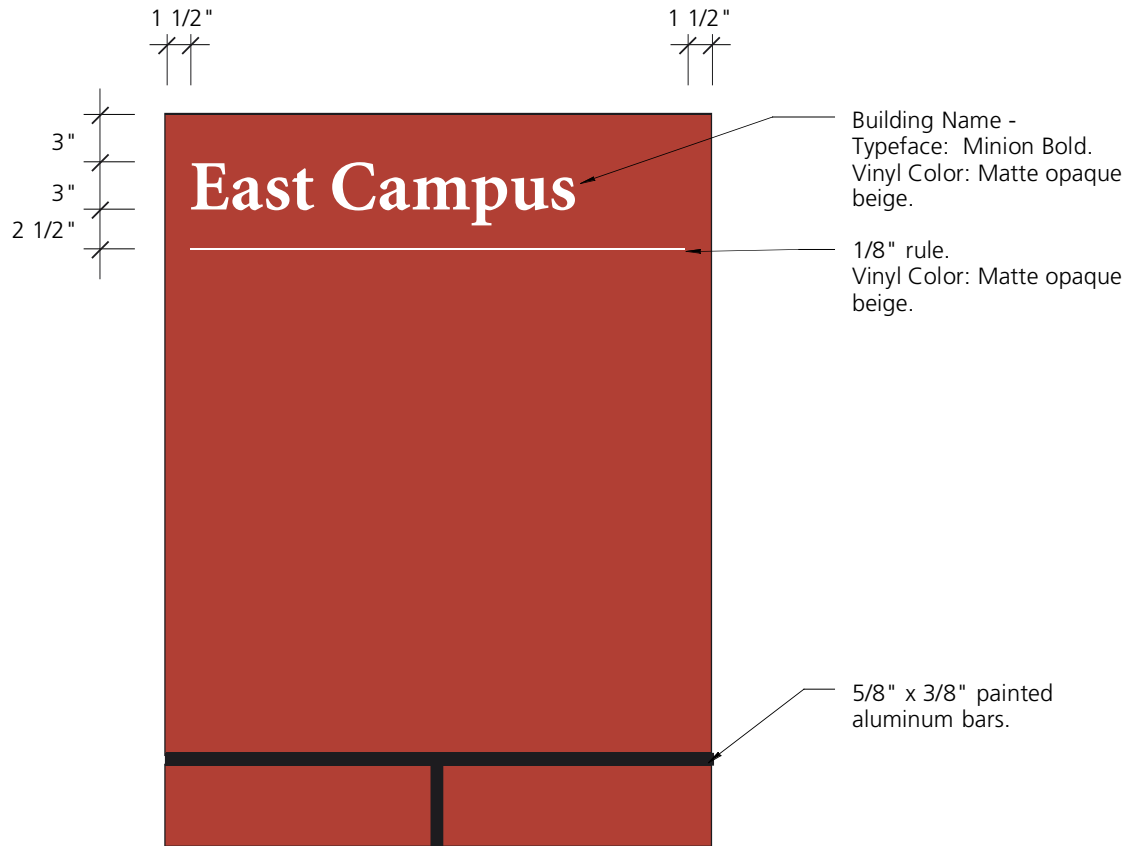

Layouts - Sign Type C.1 (single line building name)

Scale: 1" = 1'-0"

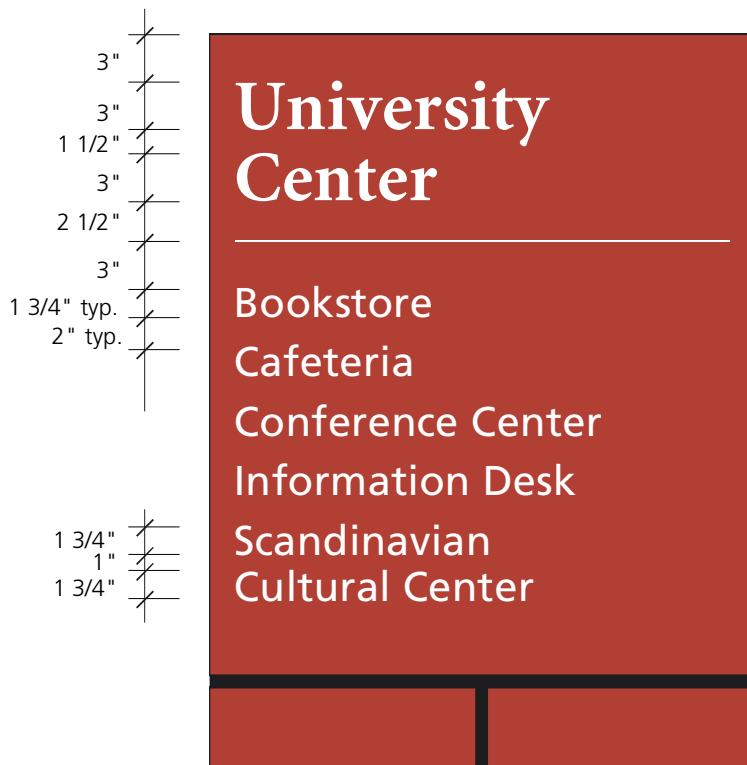
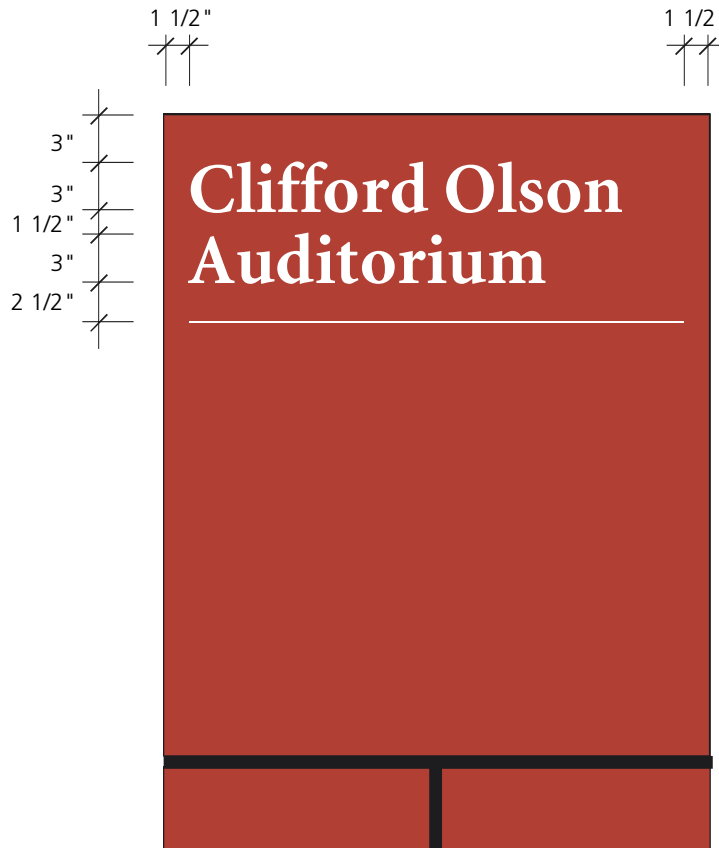

Layouts - Sign Type C.1 (double line building name)
Scale: 1" = 1'- 0"

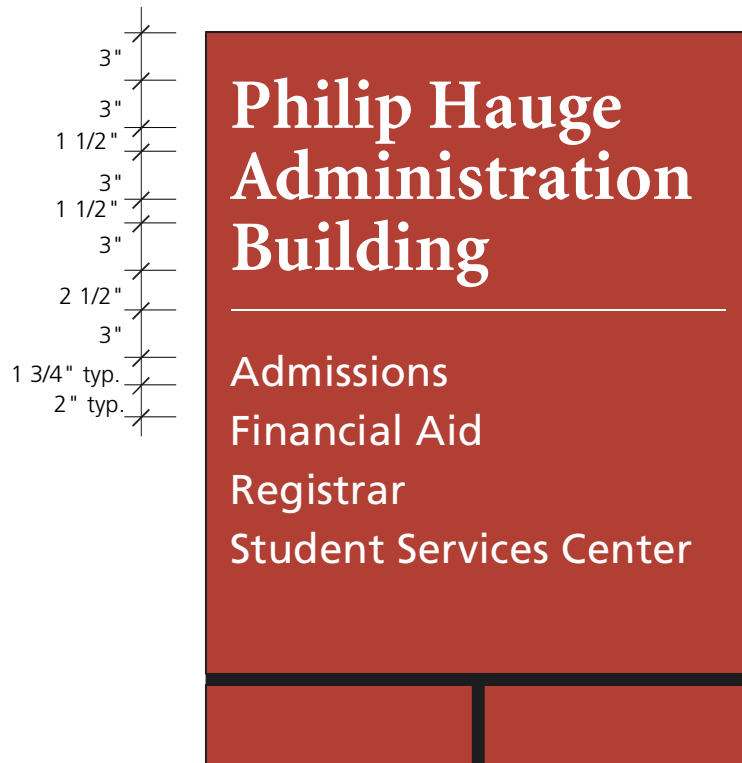
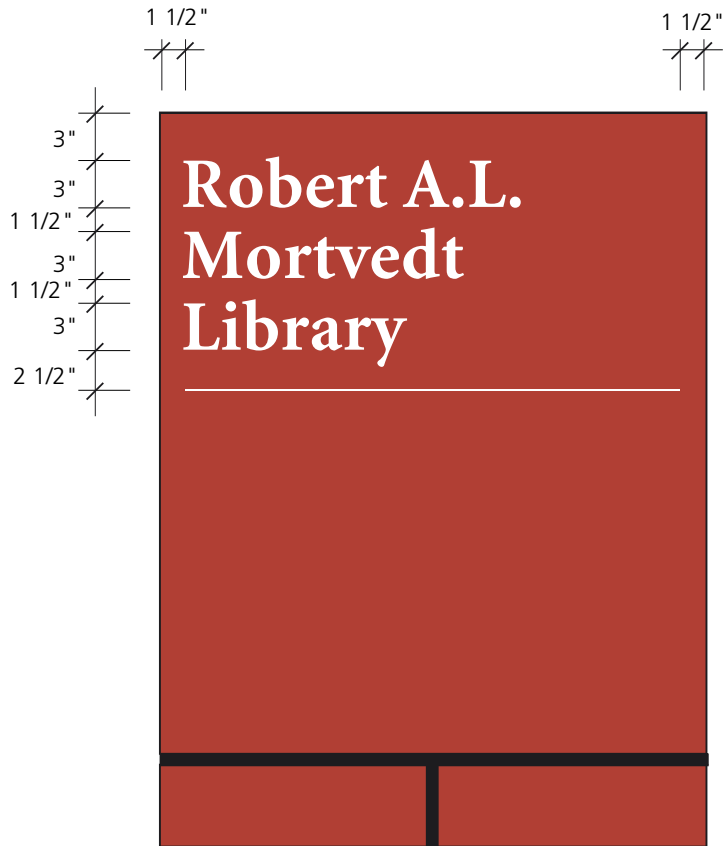

Layouts - Sign Type C.1 (triple line building name)

Scale: 1" = 1'- 0"

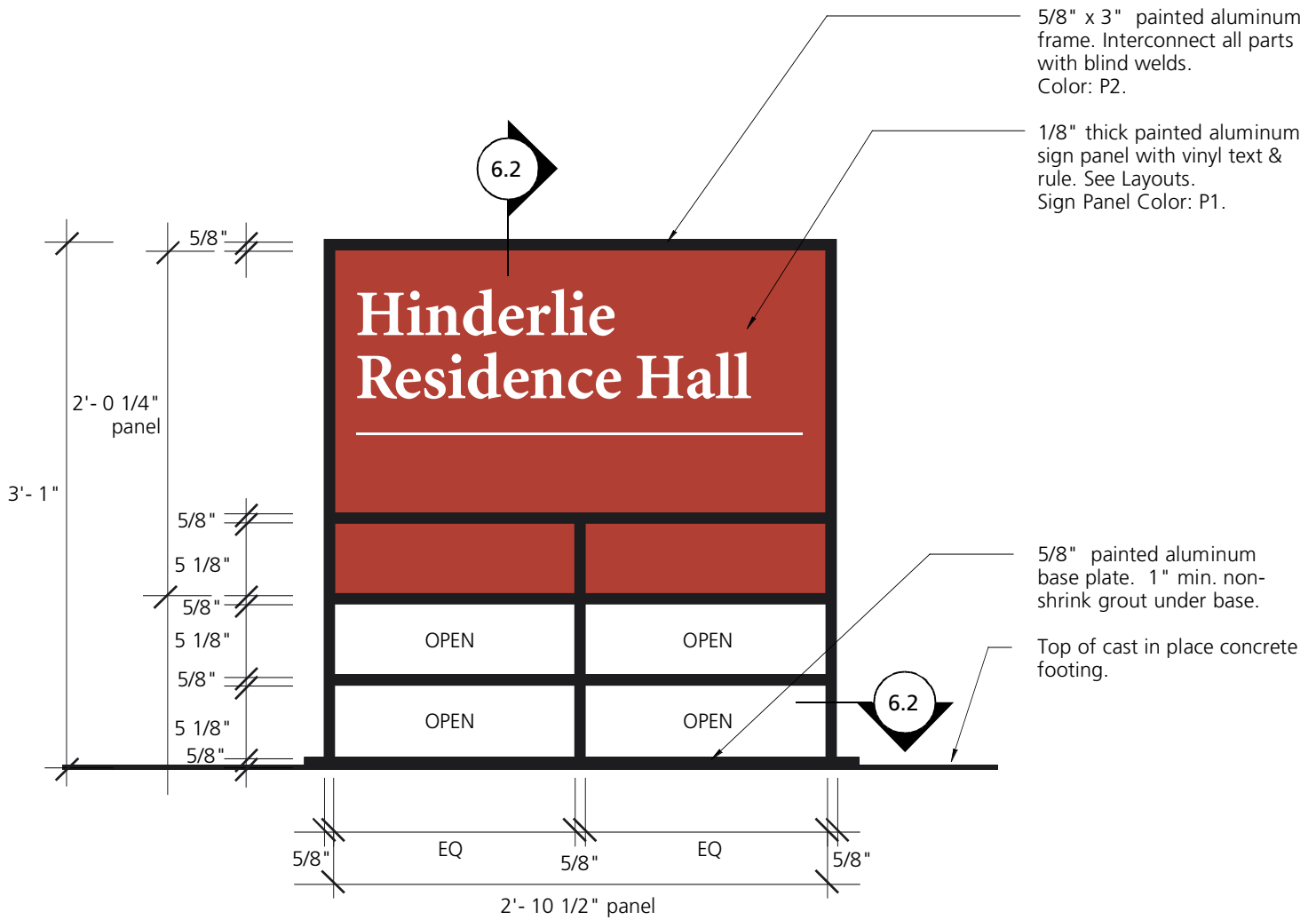

Elevation - Sign Type C.2

Scale: 1" = 1'-0"

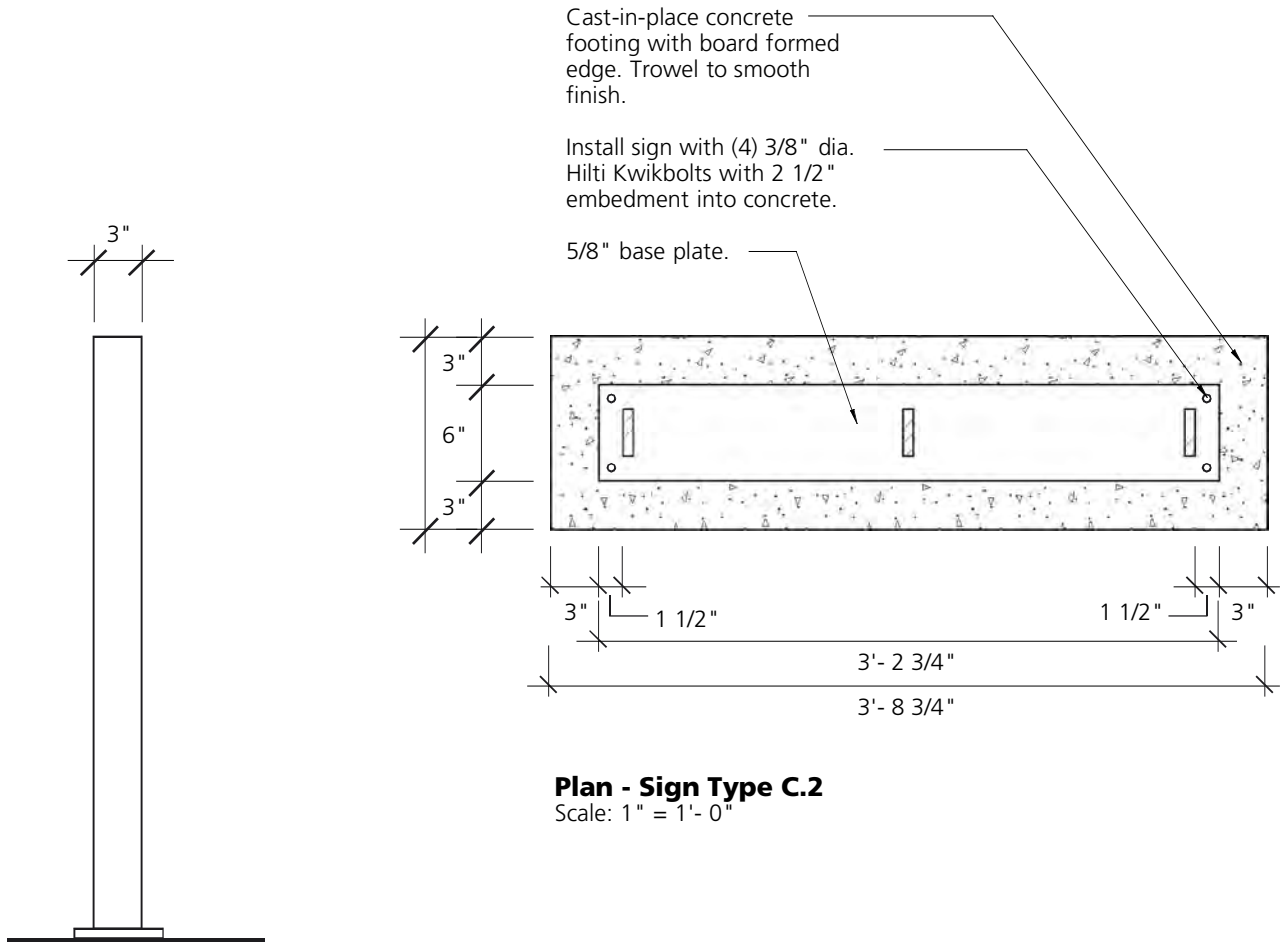

Plan - Sign Type C.2

Scale: 1" = 1'- 0"

Side View - Sign Type C.2

Scale: 1" = 1'- 0"

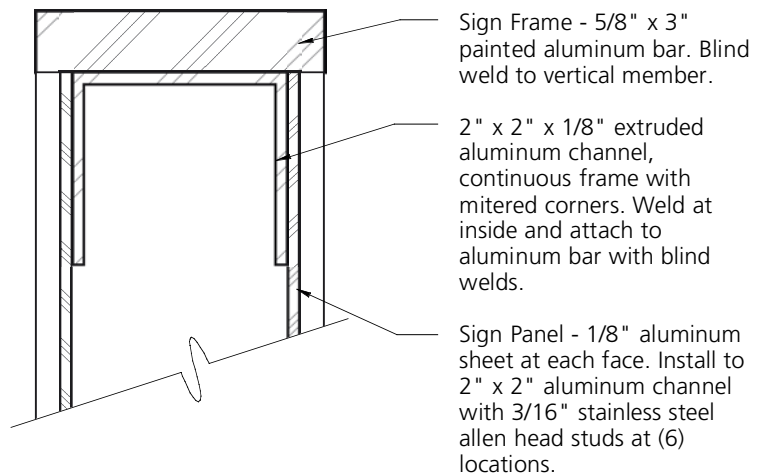

Detail at Top - Sign Type C.2

Scale: Half Full

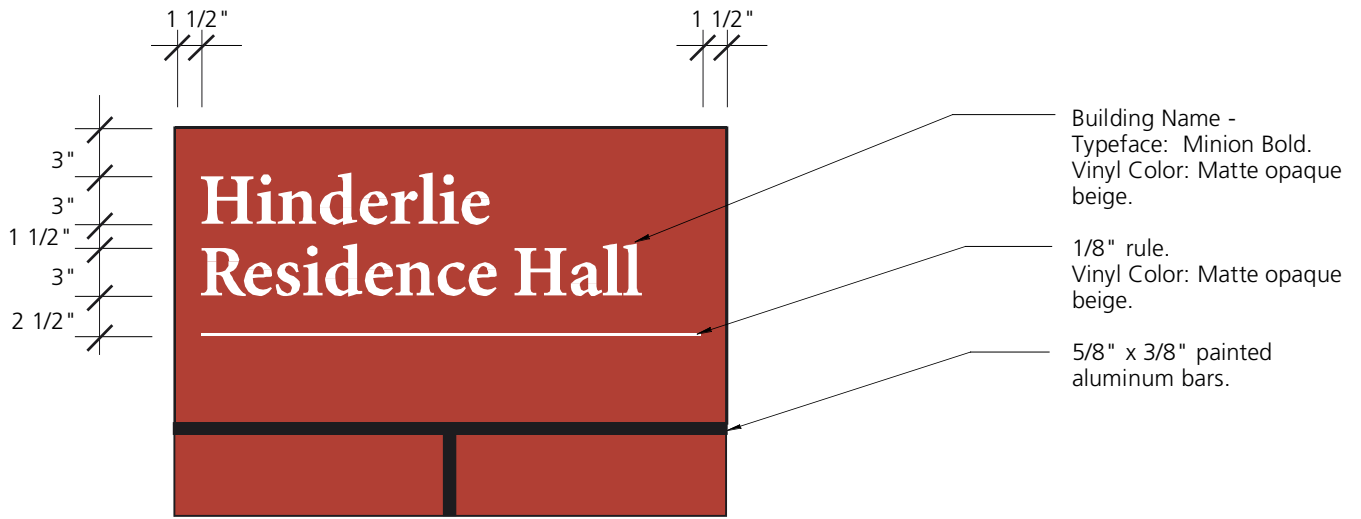

Layout - Sign Type C.2

Scale: 1" = 1'-0"

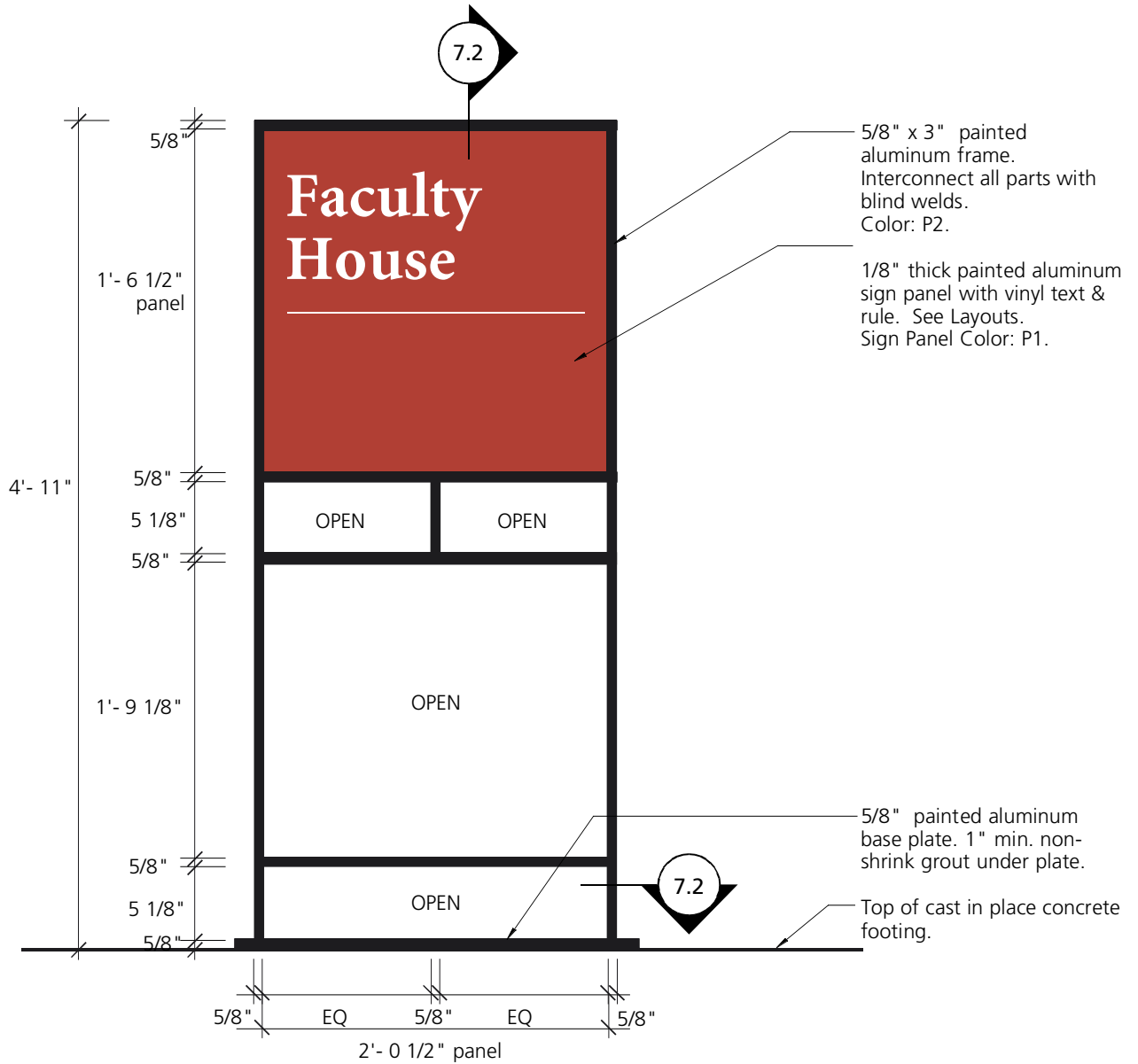

Elevation - Sign Type C.3

Scale: 1" = 1'- 0"

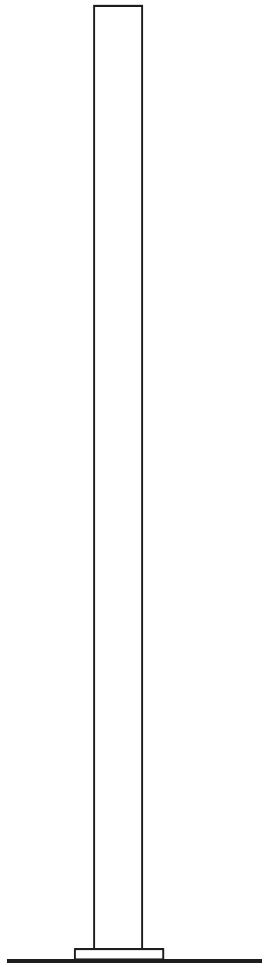

Side View - Sign Type C.3
Scale: 1" = 1'-0"

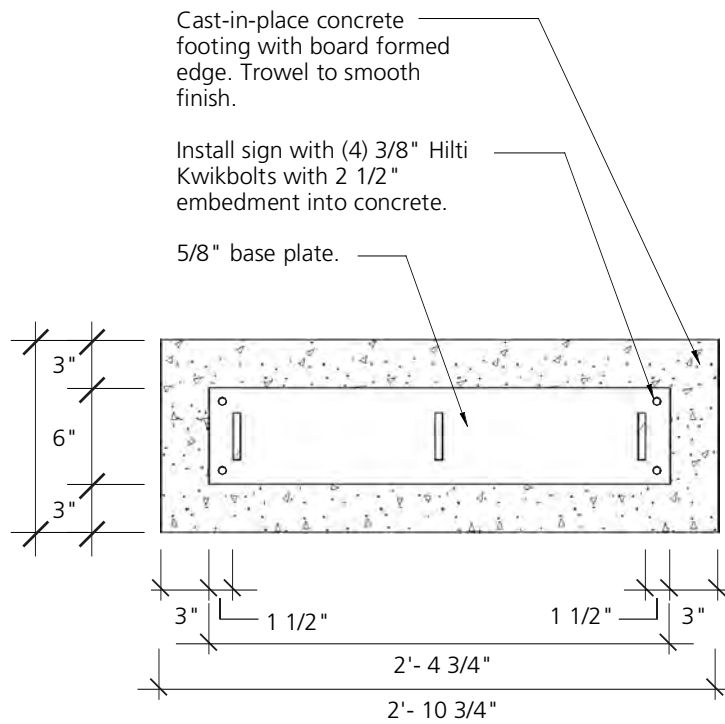

Plan - Sign Type C.3
Scale: 1" = 1'-0"

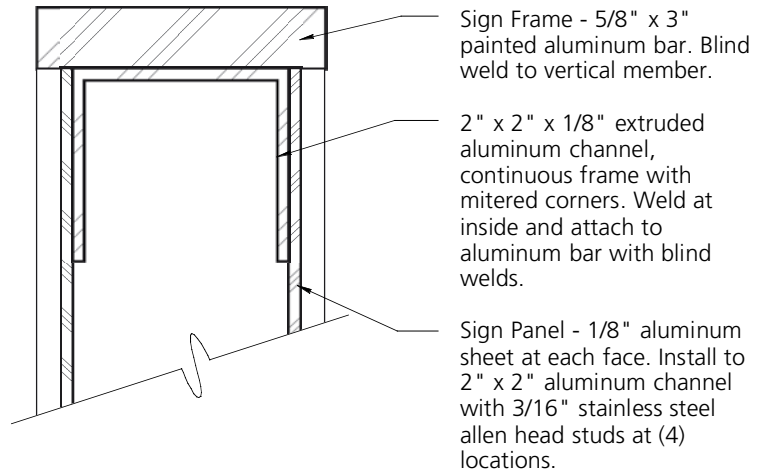

Detail at Top - Sign Type C.3
Scale: Half Full

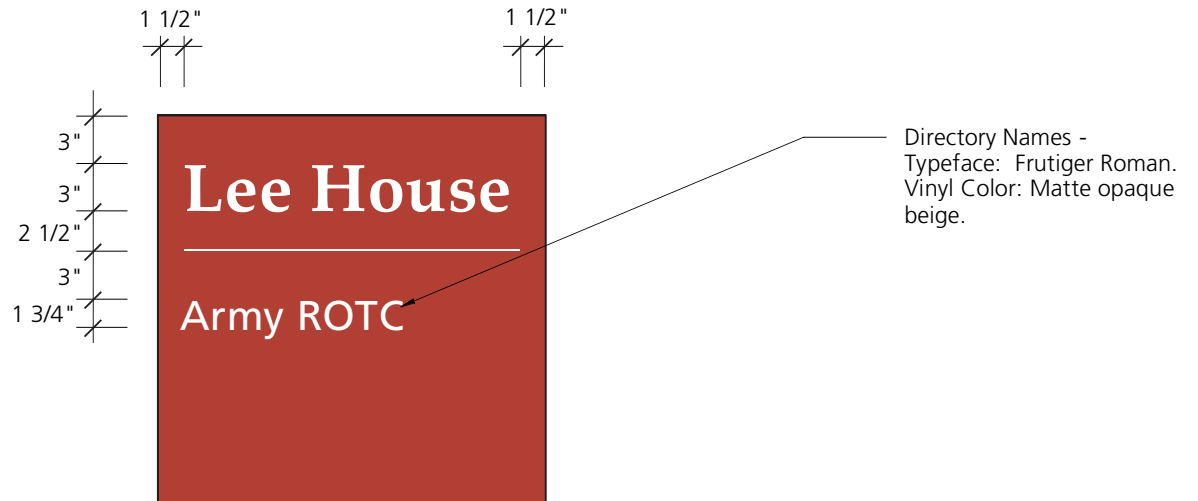
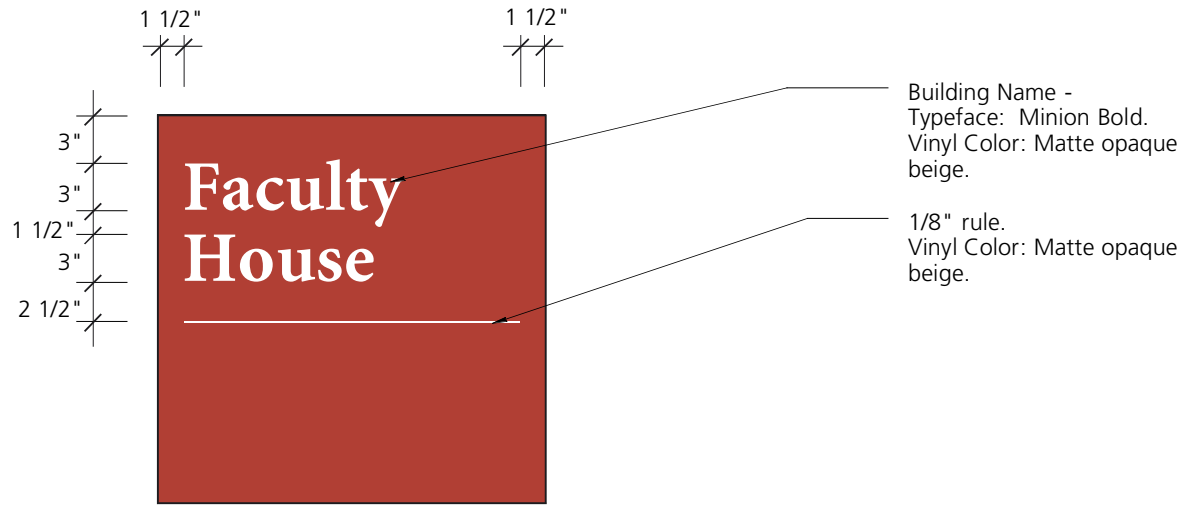

Layout - Sign Type C.3
Scale: 1" = 1'-0"

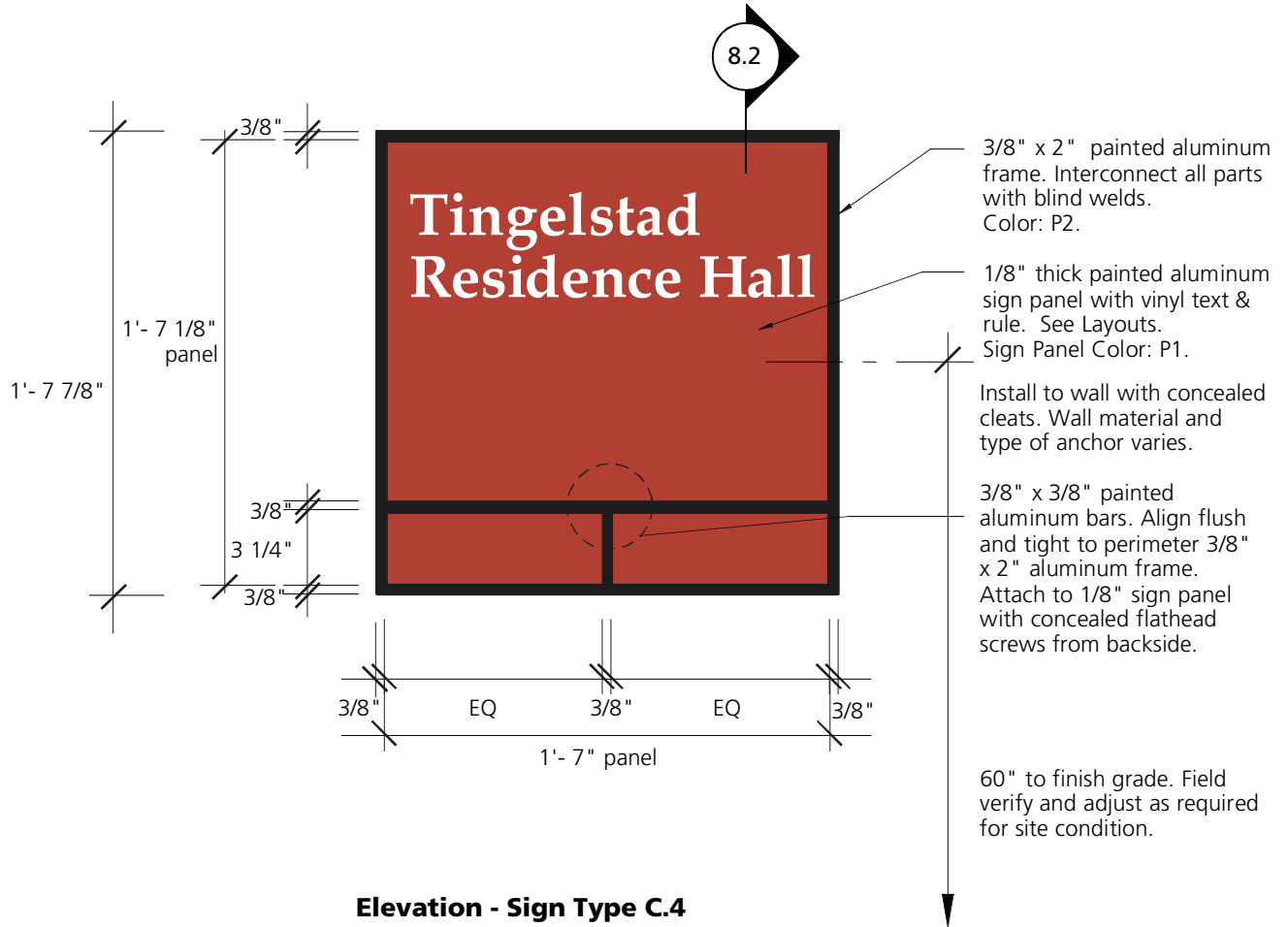

Elevation - Sign Type C.4

Scale: 1 1/2" = 1'- 0"

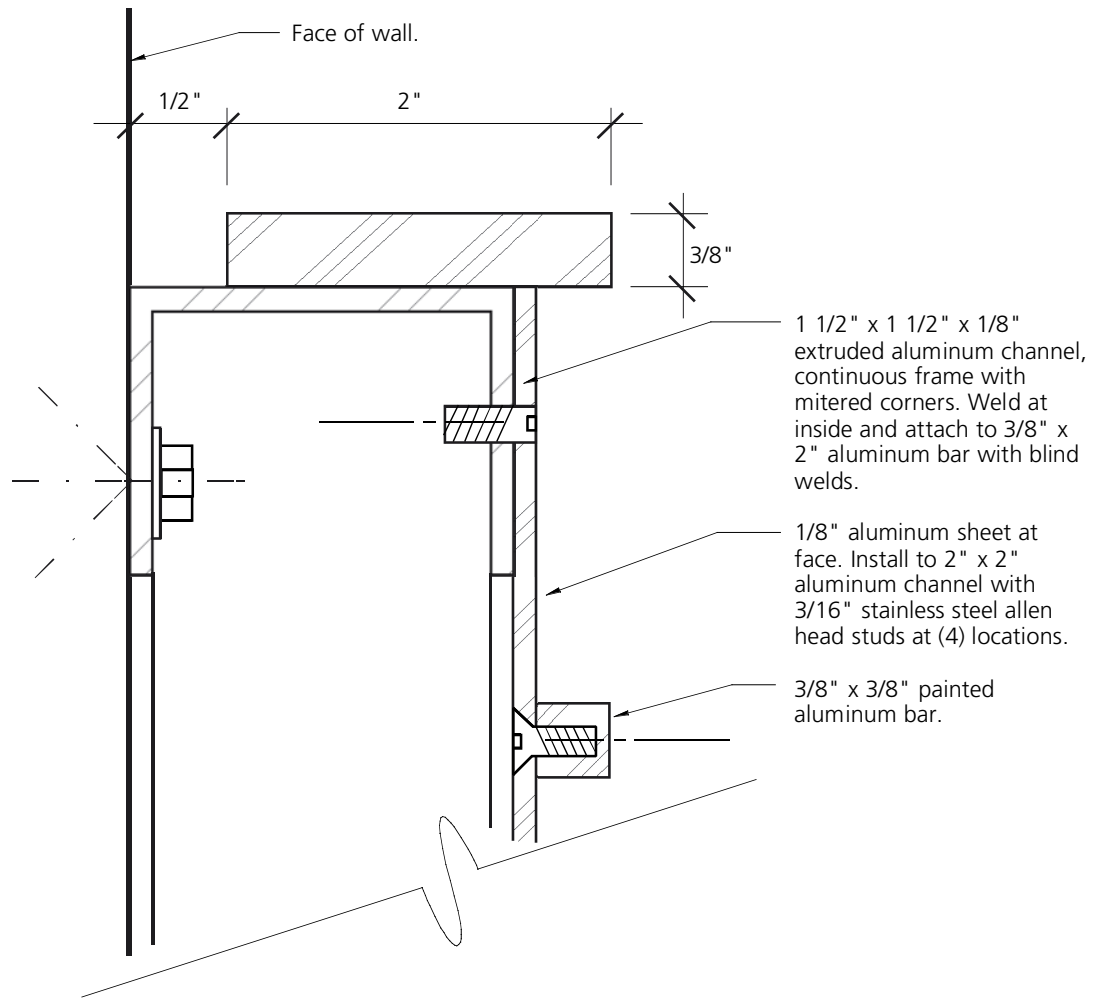

Detail at Top - Sign Type C.4

Scale: Full

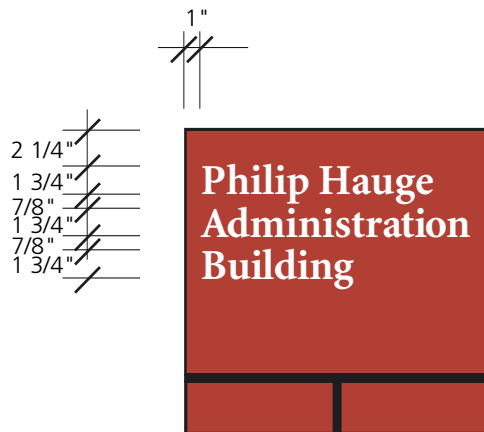
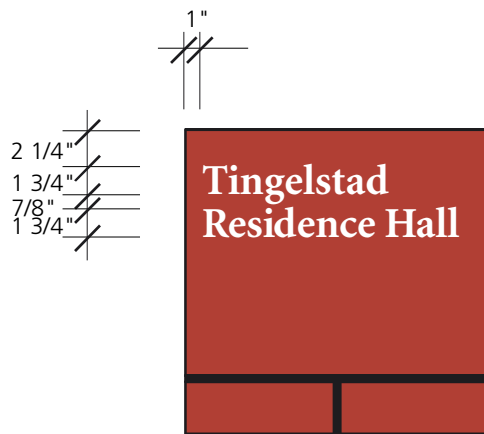
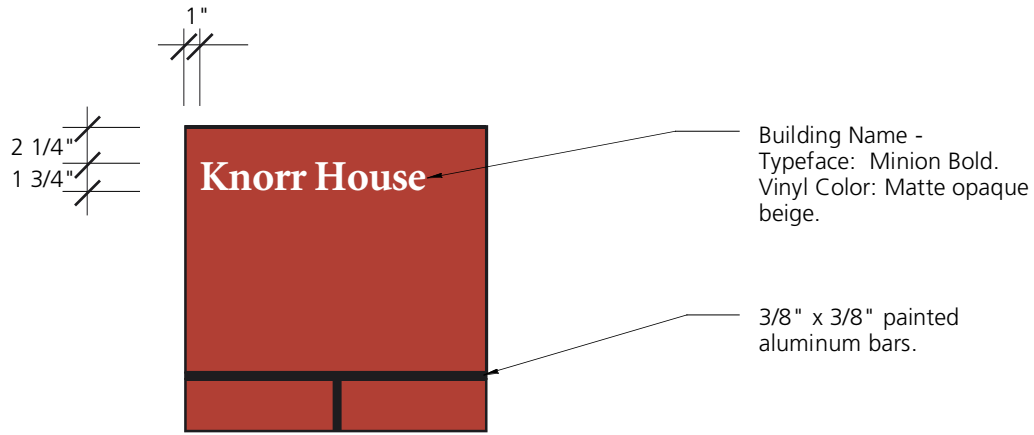

Layout - Sign Type C.4

Scale: 1" = 1'- 0"

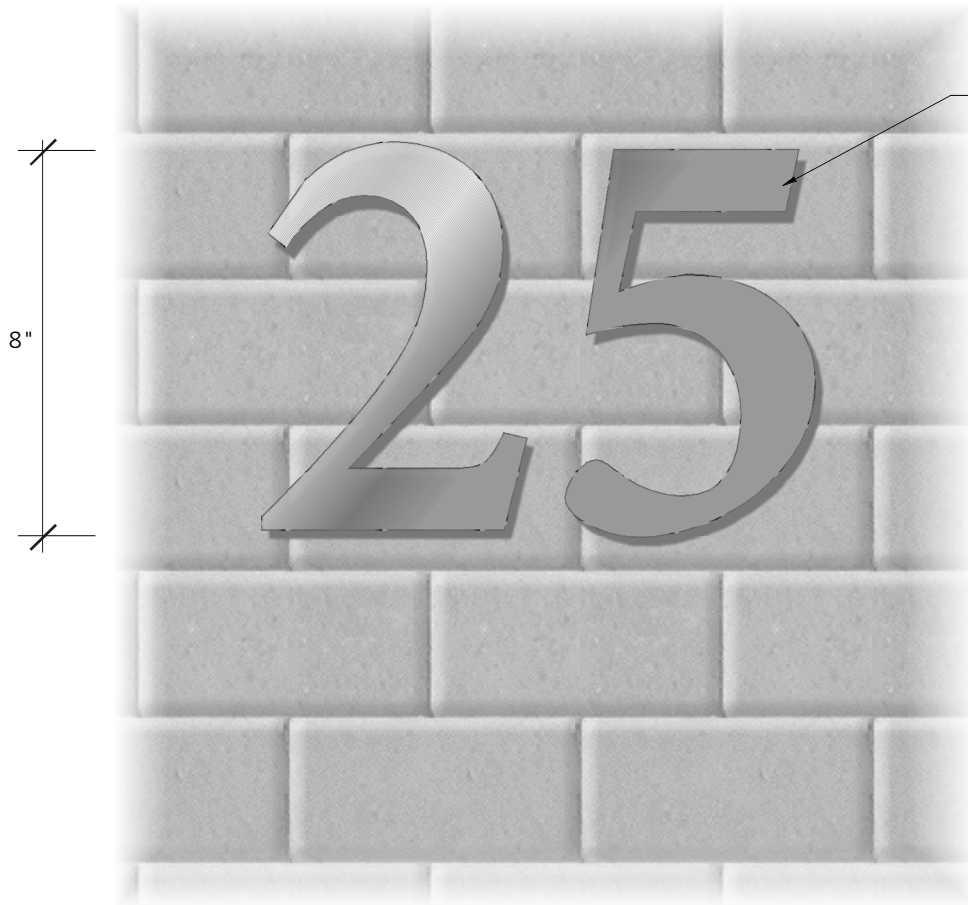

Building Number -
1/4" thick aluminum
dimensional letters. Install
with threaded stainless
steel studs set in epoxy
Finish: As indicated on sign
schedule.
Typeface: Minion Bold.

Mounting position to be
field verified by Fire
Marshall.

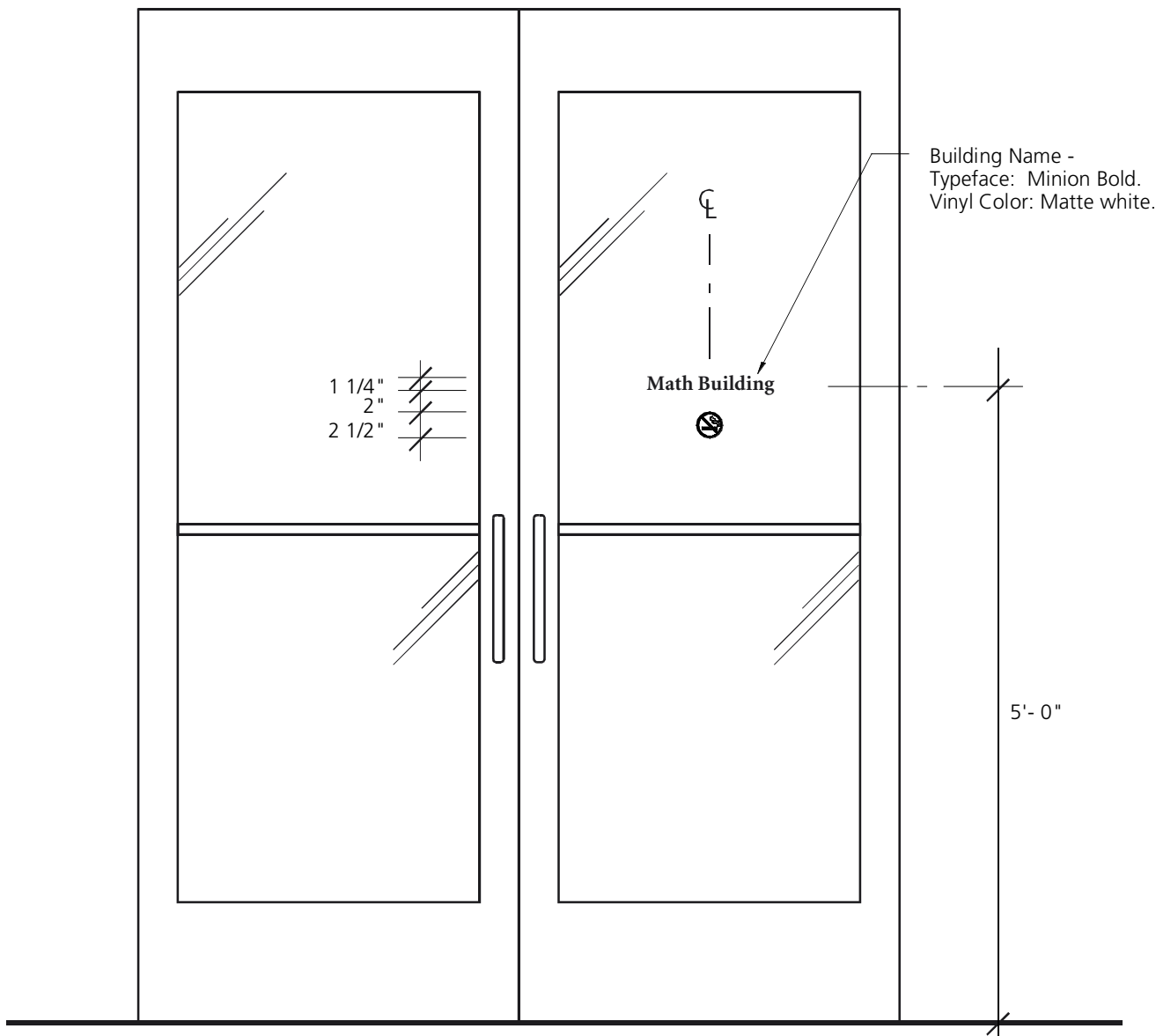

Typical Mounting Condition - Sign Type D

Scale: 3/4" = 1'-0"

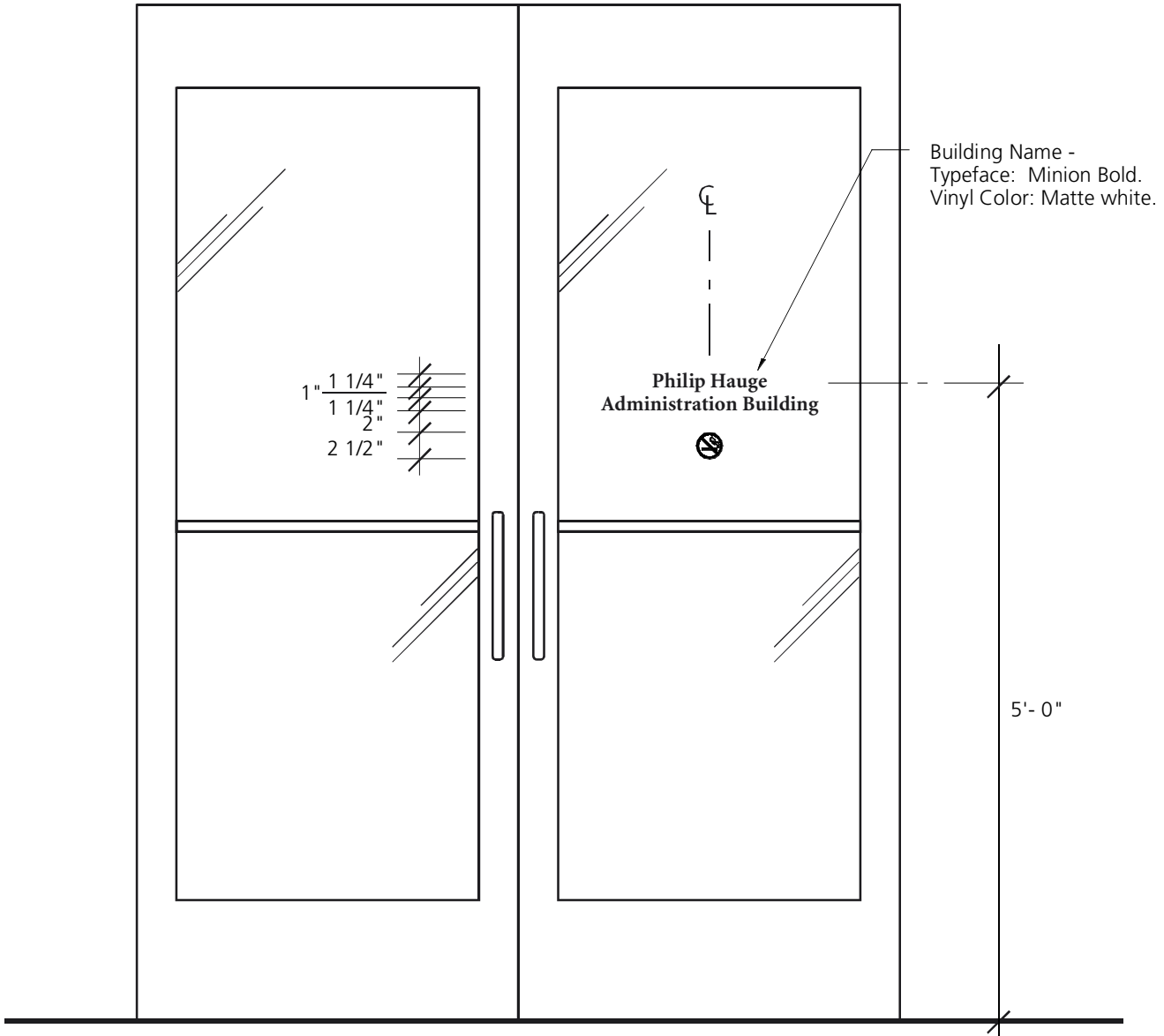

Typical Mounting Condition - Sign Type D

Scale: 3/4" = 1'-0"

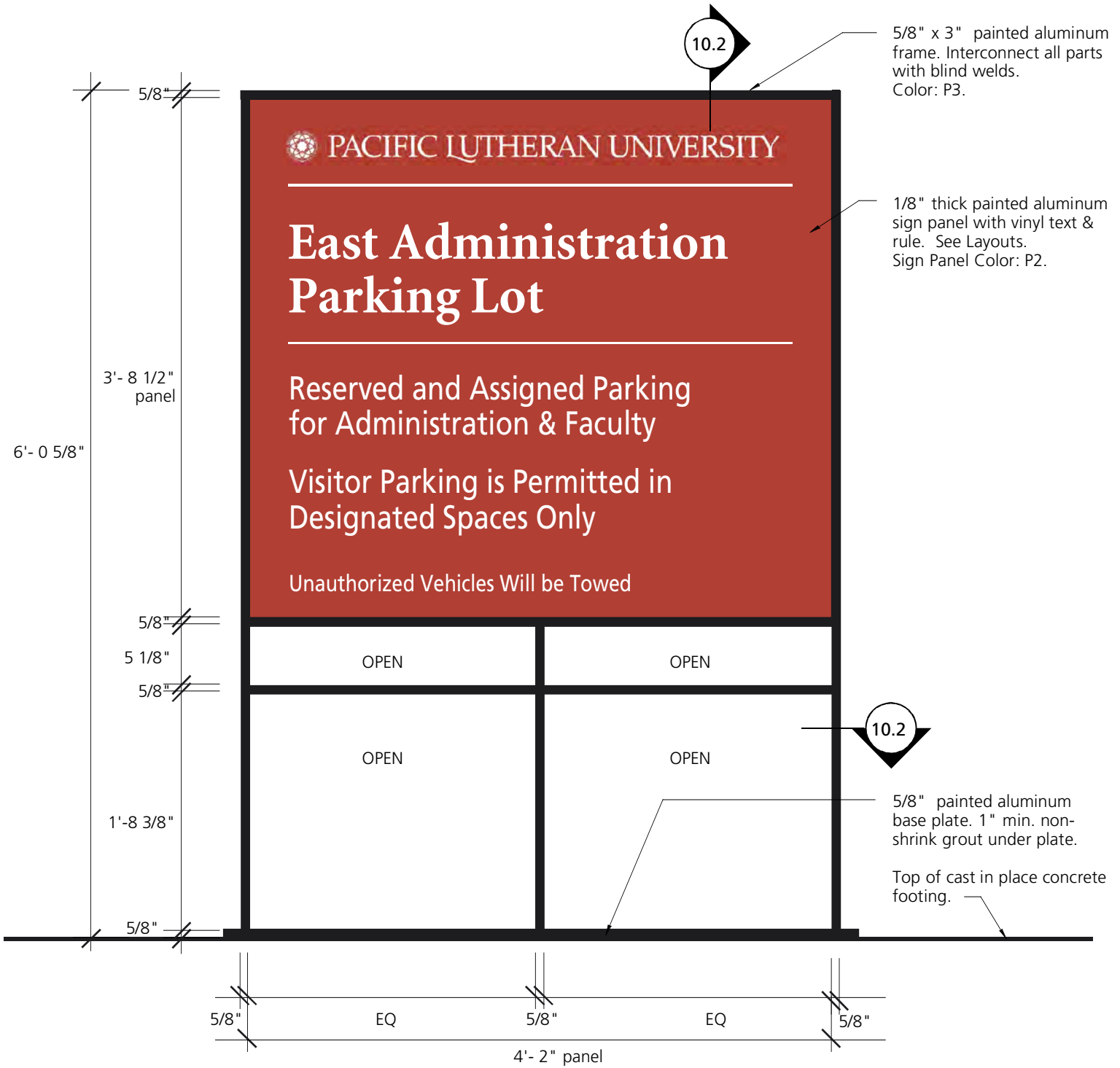

Elevation - Sign Type E

Scale: 1" = 1'-0"

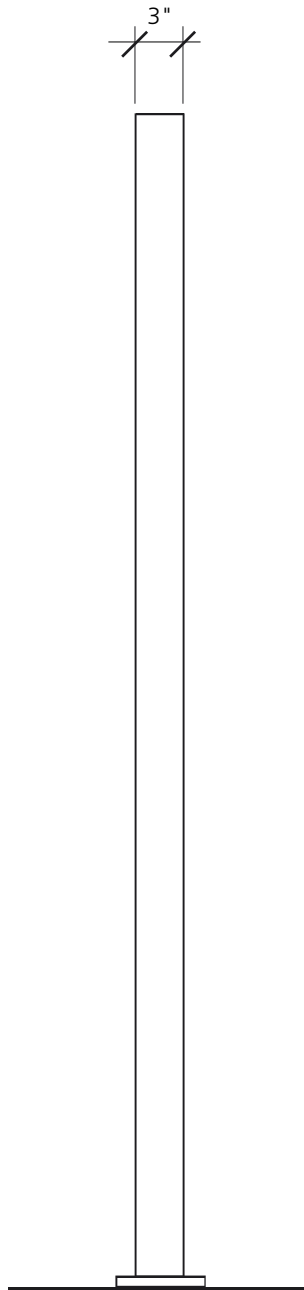

Side View - Sign Type E
Scale: 1" = 1'-0"

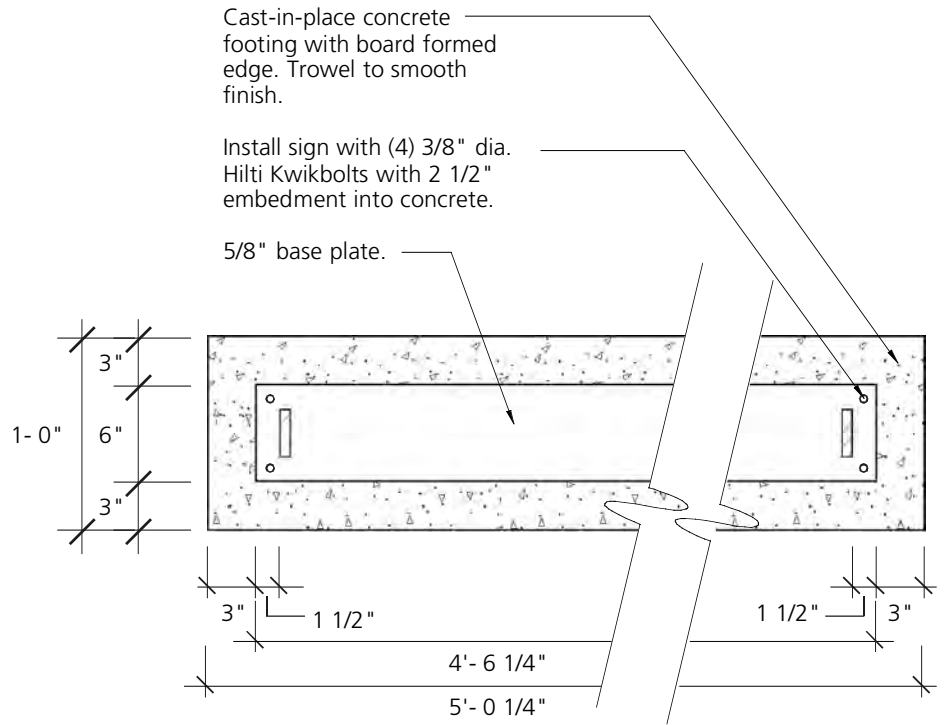

Plan - Sign Type E
Scale: 1" = 1'-0"

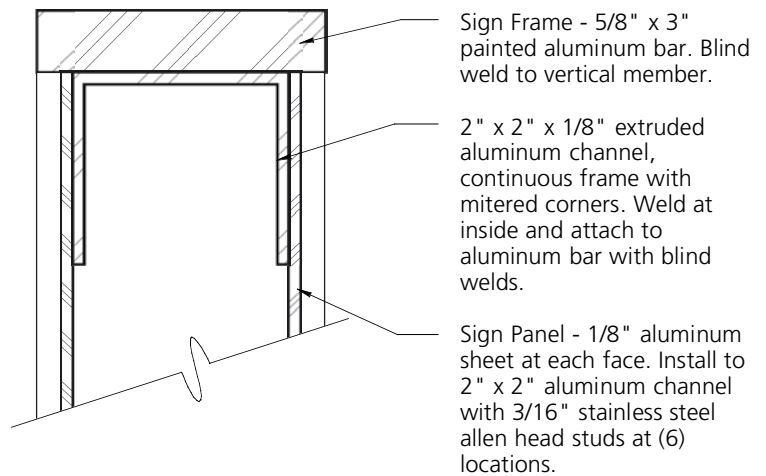

Detail at Top - Sign Type E
Scale: Half Full

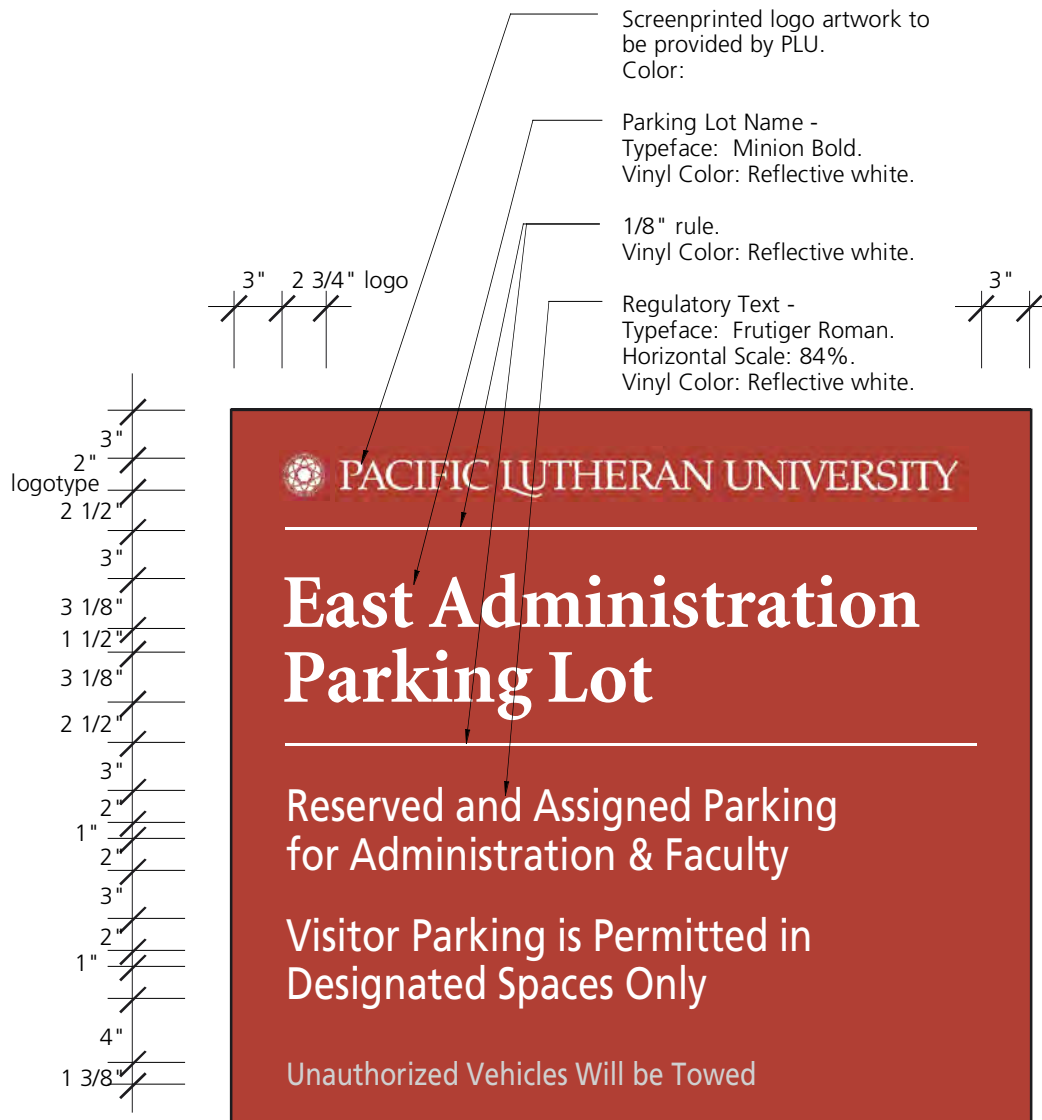

Layout - Sign Type E

Scale: 1" = 1'-0"

Note: Regulatory text is shown for basic style and layout only. Owner will provide final text requirements.

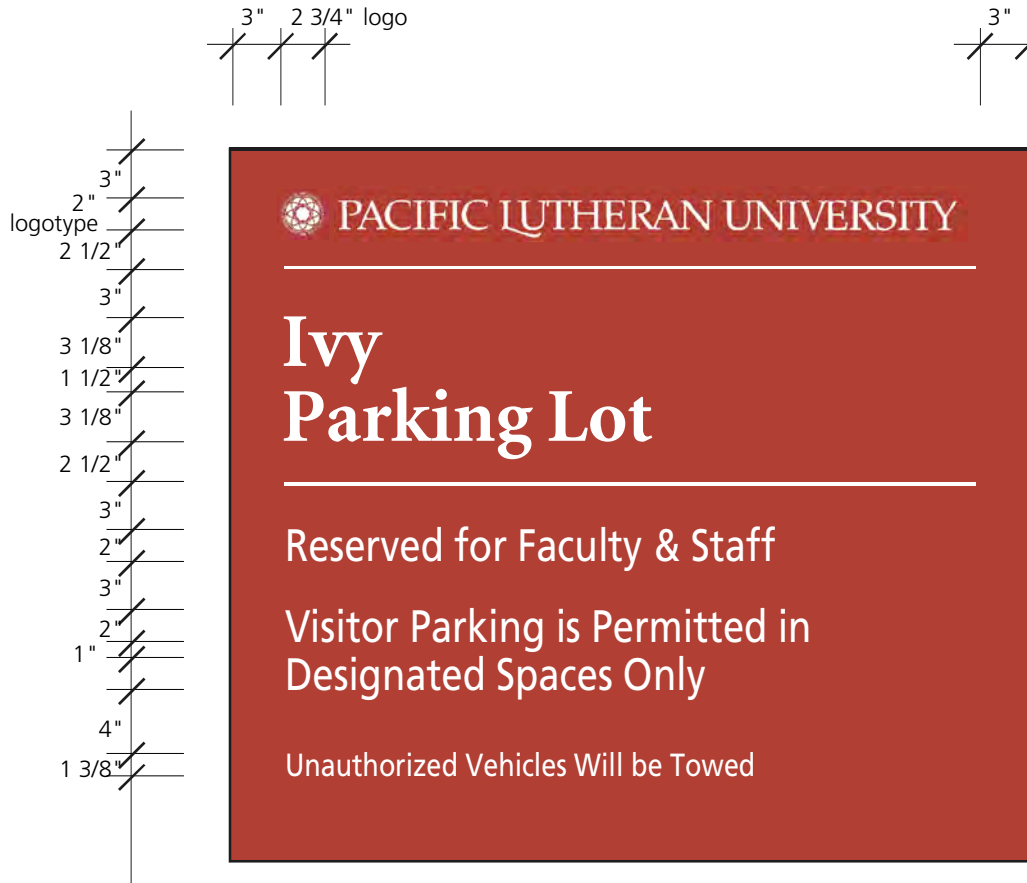

Layout - Sign Type E

Scale: 1" = 1'-0"

Note: Regulatory text is shown for basic style and layout only. Owner will provide final text requirements.

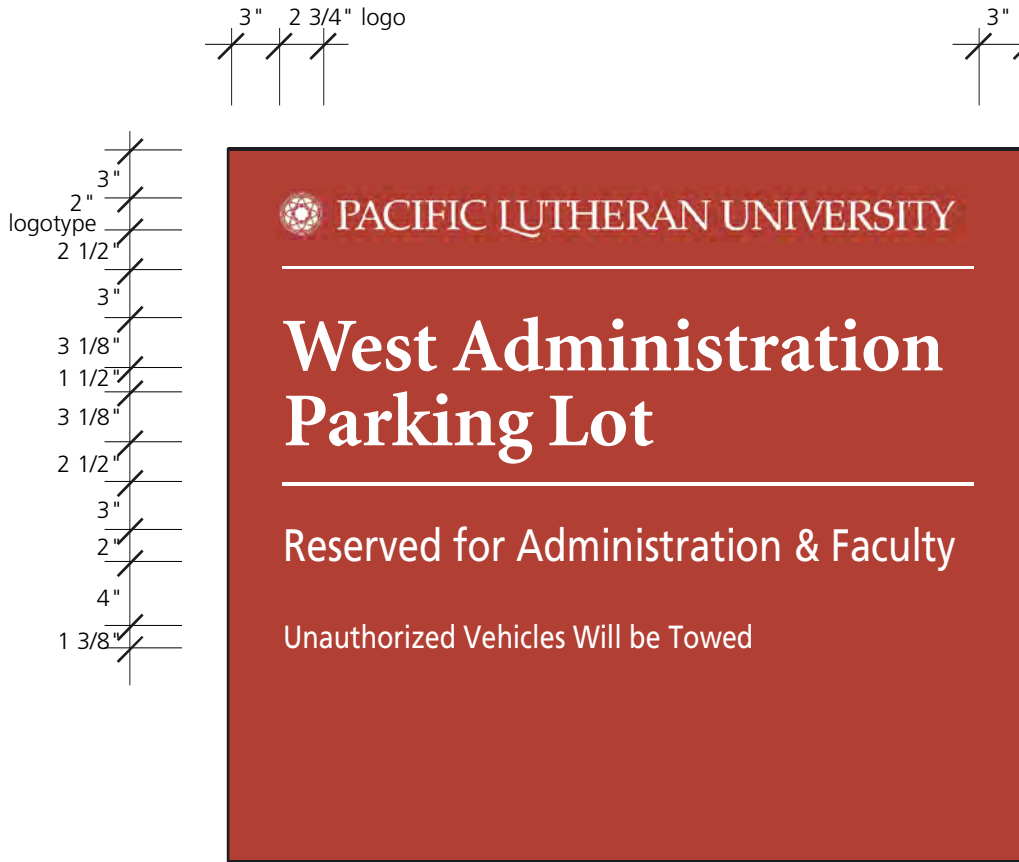

Layout - Sign Type E
Scale: 1" = 1'-0"

Note: Regulatory text is shown for basic style and layout only. Owner will provide final text requirements.

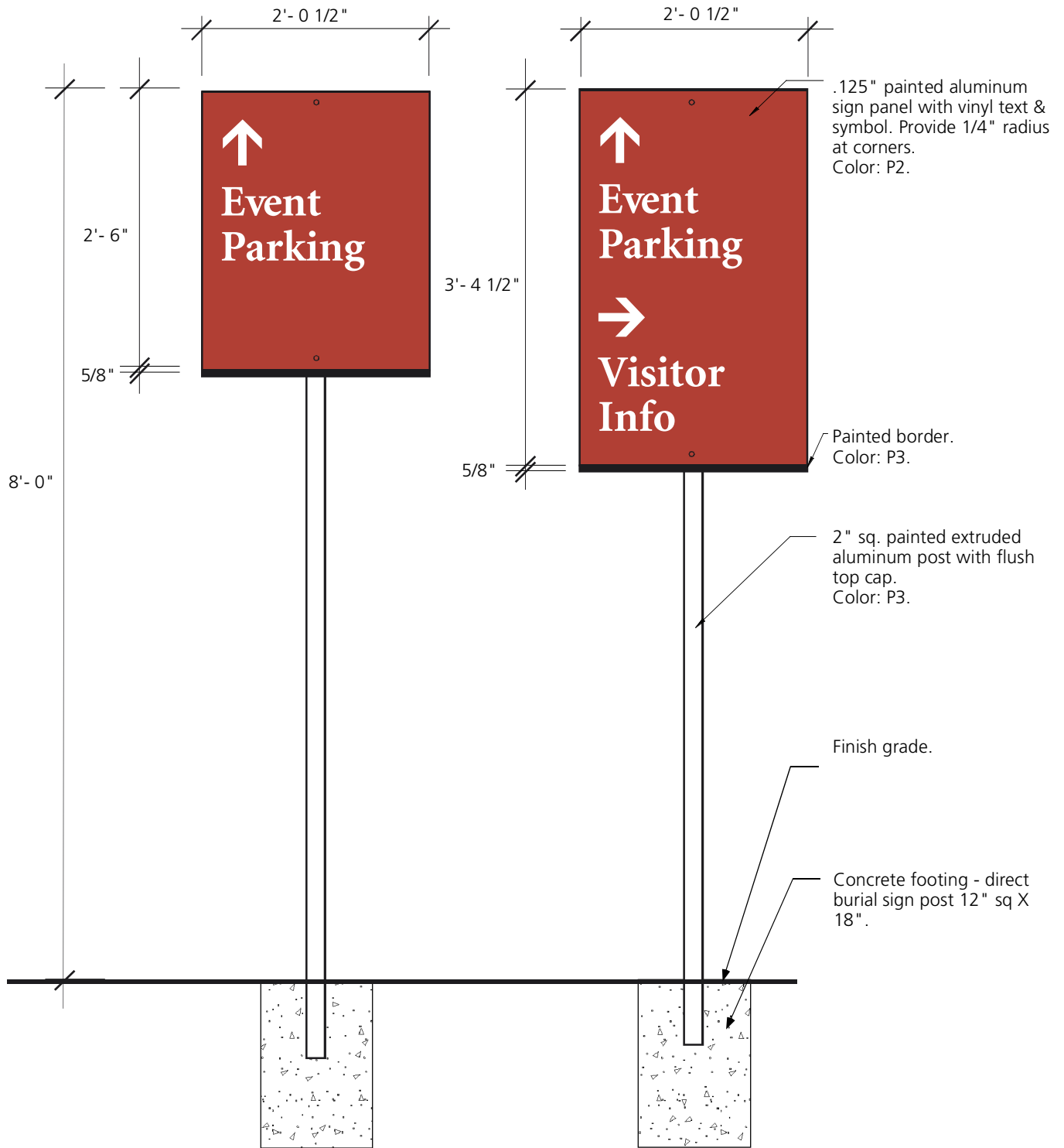

Elevation - Sign Type F

Scale: 3/4" = 1'-0"

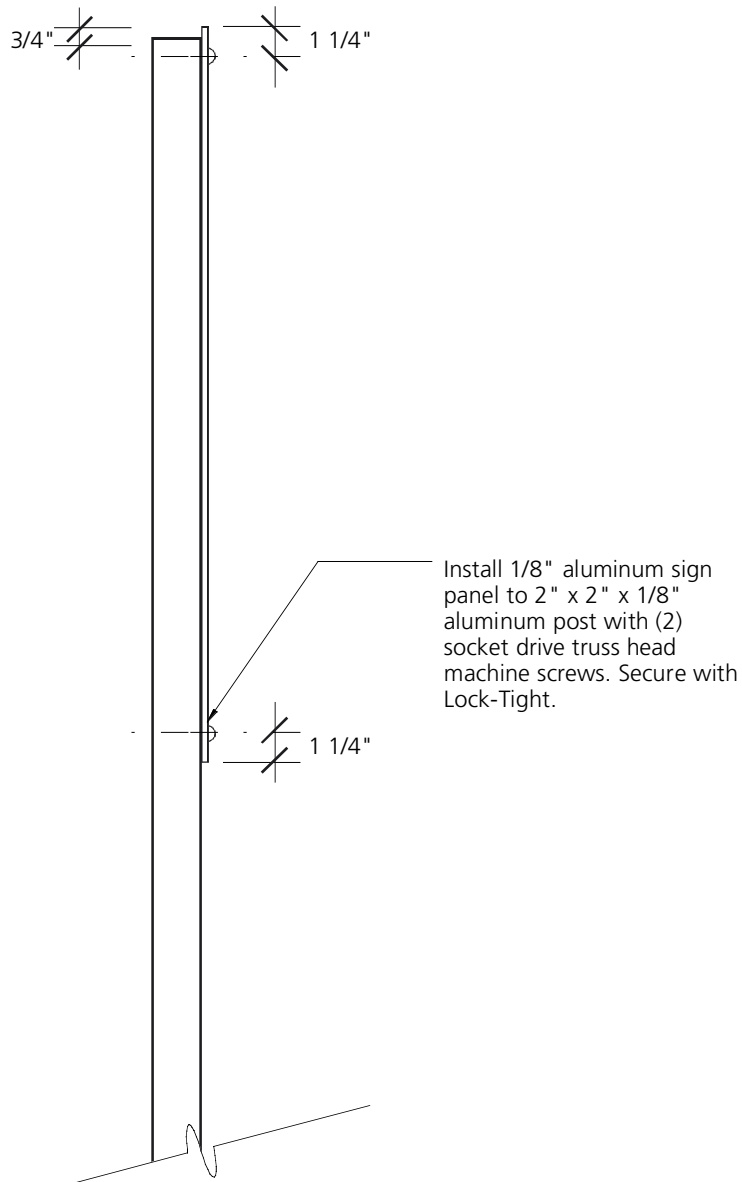

Side View - Sign Type F

Scale: 1 1/2" = 1'-0"

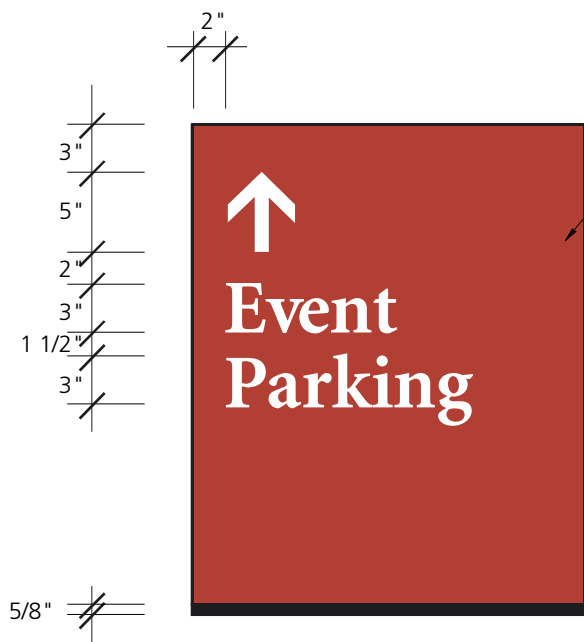

Vinyl Text & Symbol Color: Reflective white.
Typeface: Minion Bold .



Layouts - Sign Type F

Scale: 1" = 1'-0"

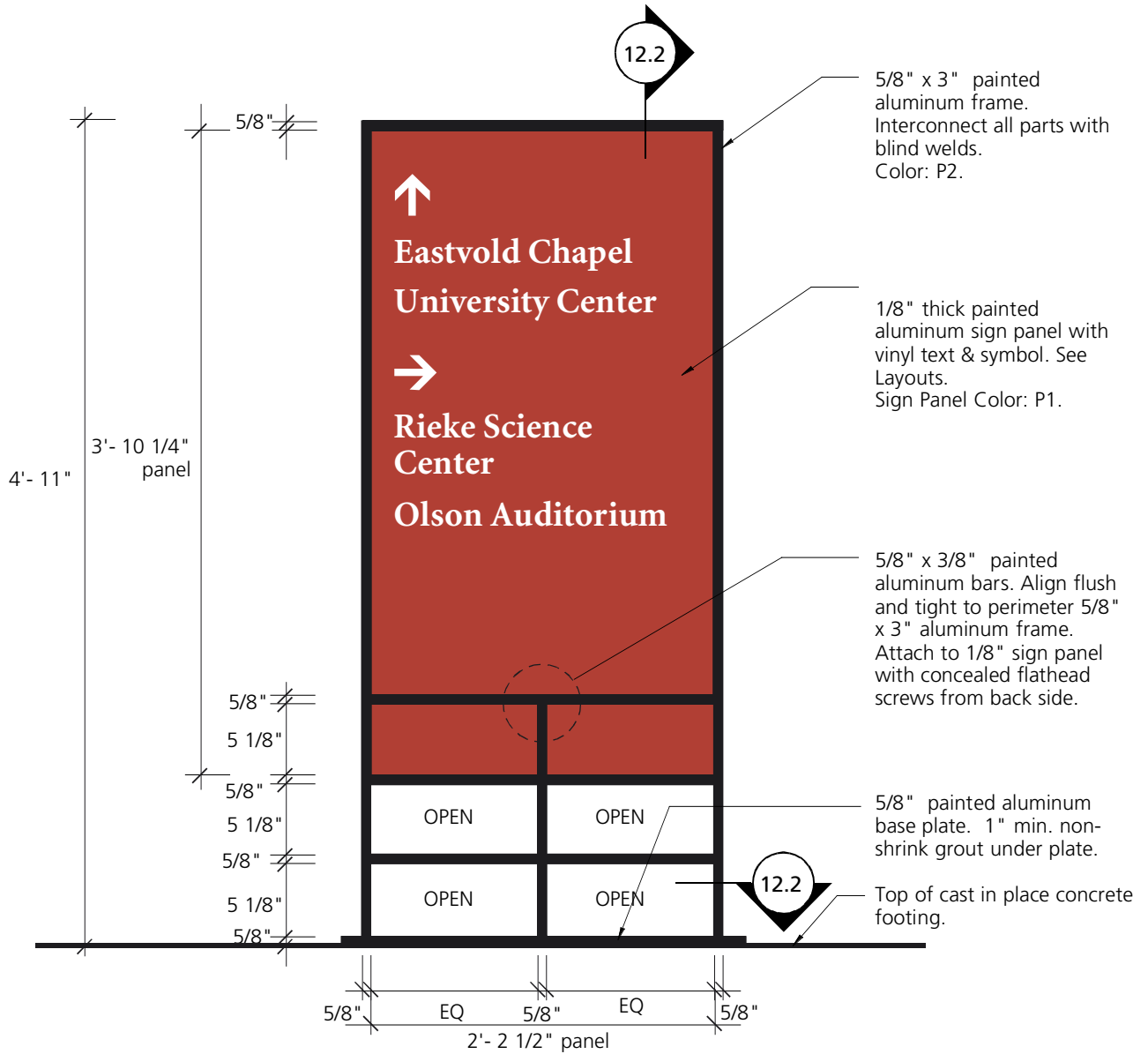

Elevation - Sign Type G

Scale: 1" = 1'- 0"

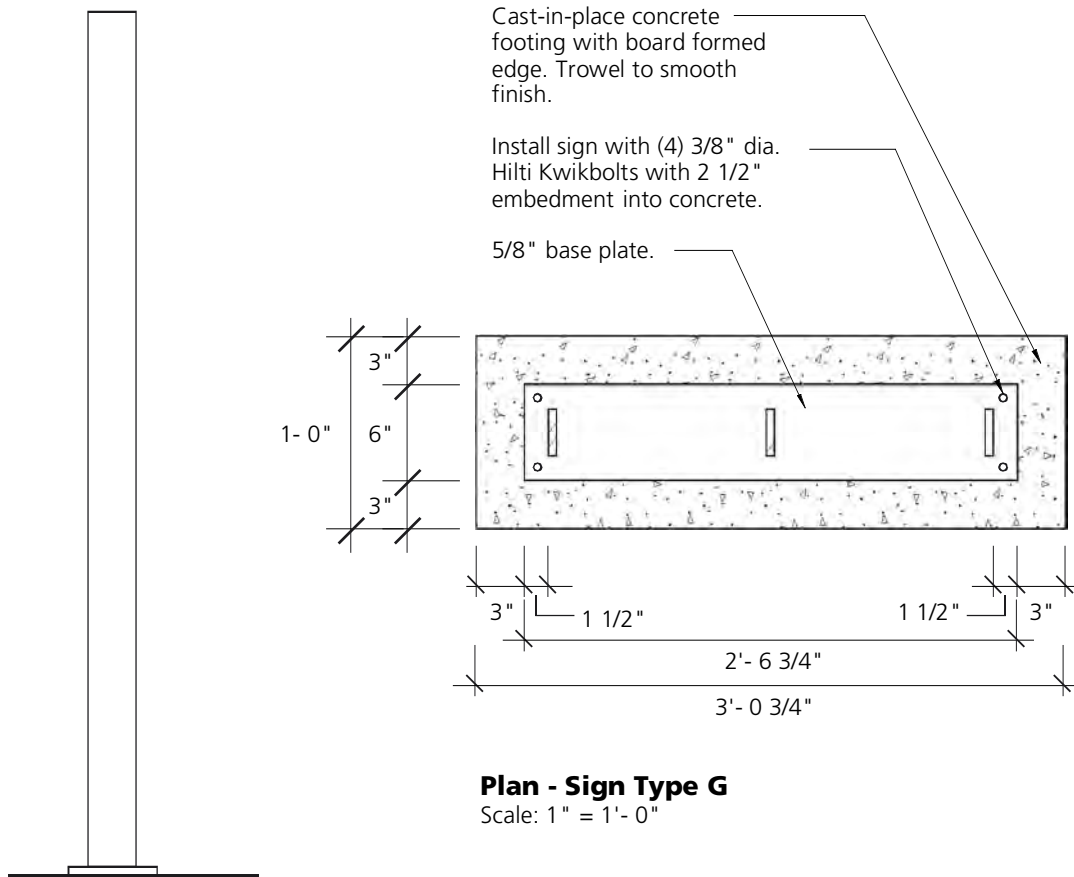

Side View - Sign Type G
Scale: 1" = 1'-0"

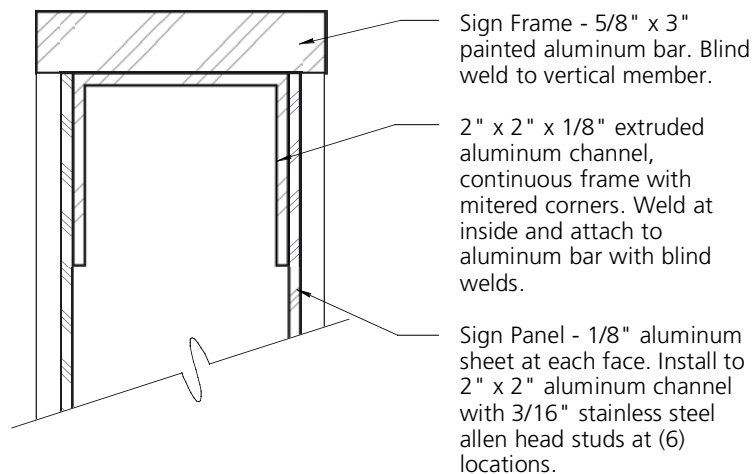

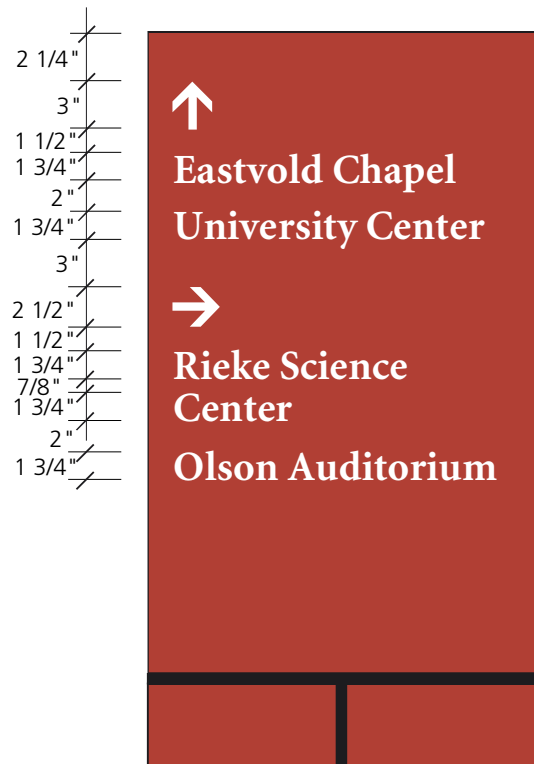
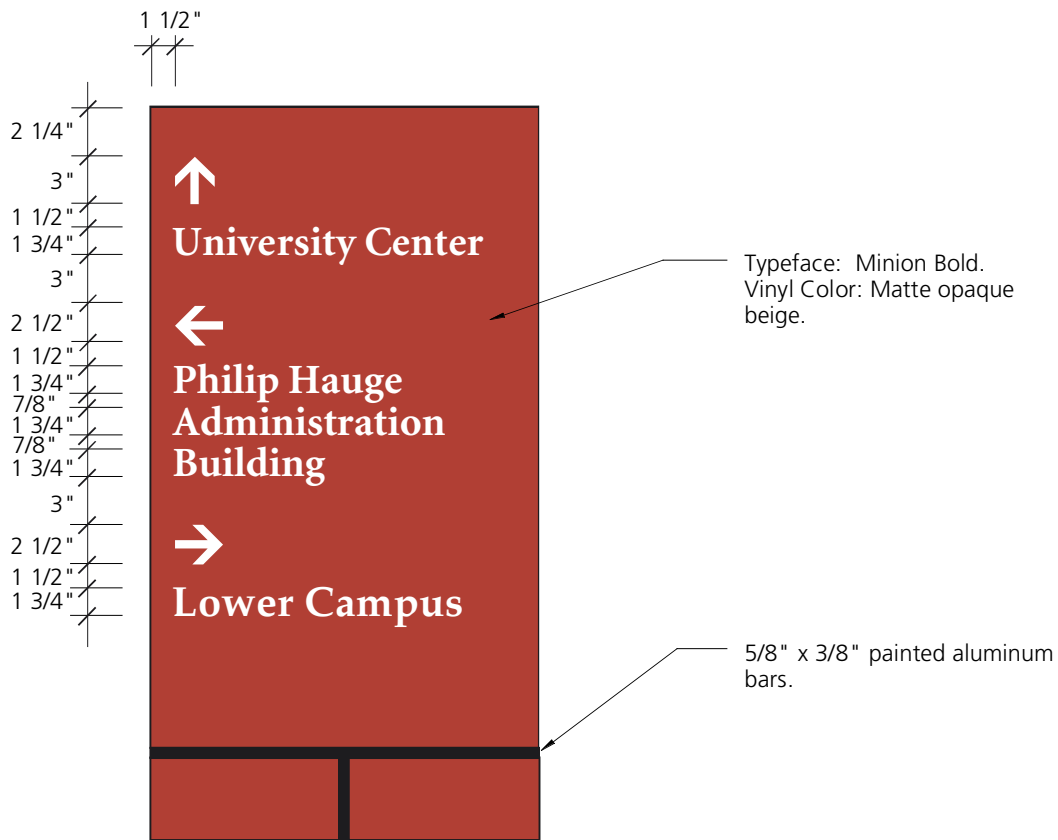

Layouts - Sign Type G
Scale: 1" = 1'-0"

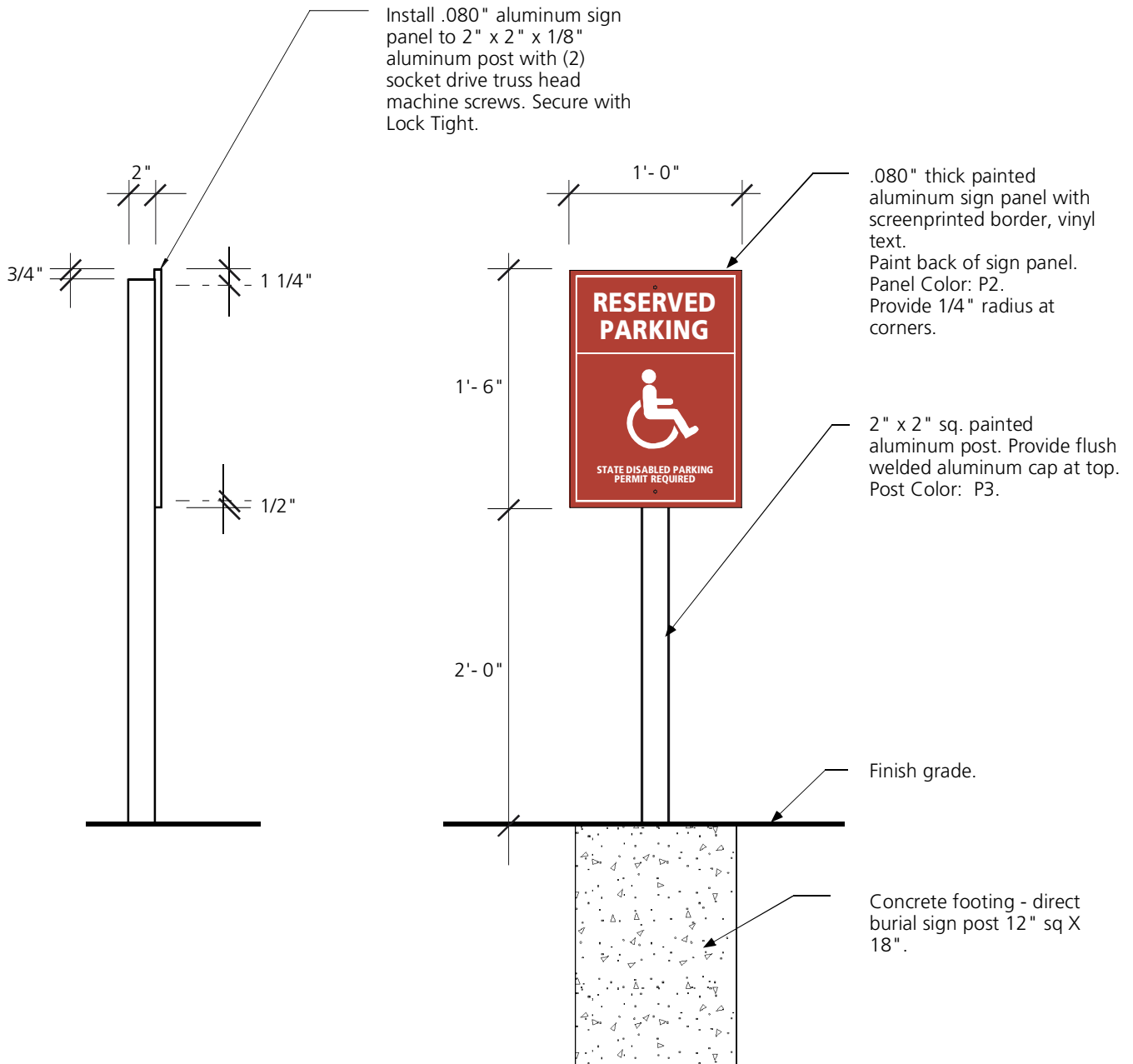

Side View - Sign Type H

Scale: 1" = 1'-0"

Elevation - Sign Type H

Scale: 1" = 1'-0"

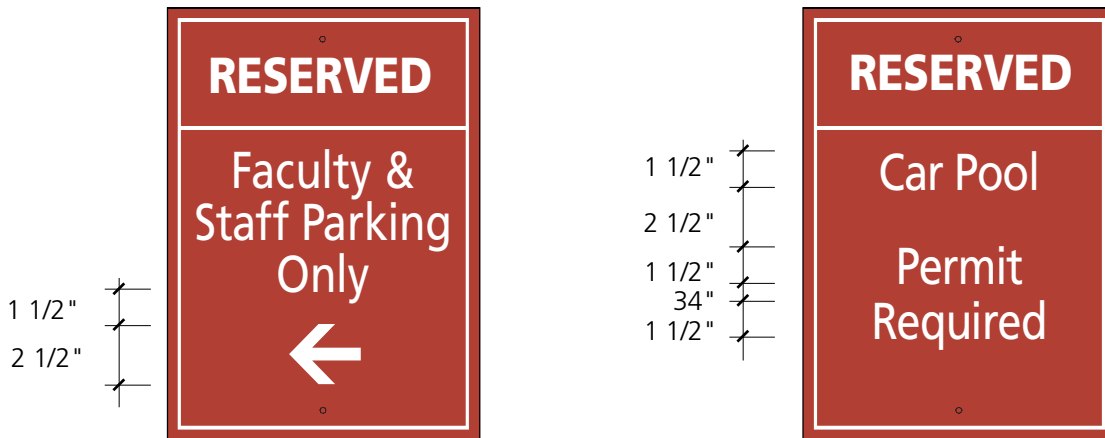
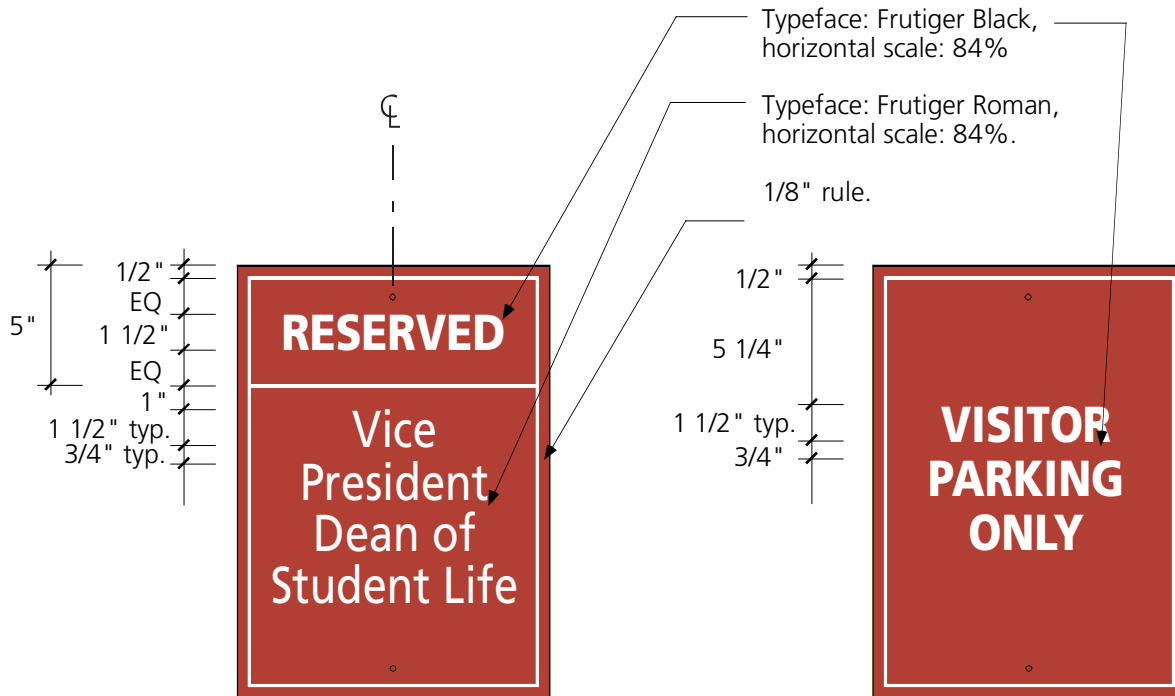

Layouts - Sign Type H
Scale: 1 1/2" = 1'-0"

ABCDEFGHIJKLM
NOPQRSTUVWXYZ
abcdefghijklmnop
qrstuvwxyz
1234567890!?

Minion Bold

ABCDEFGHIJKLM
NOPQRSTUVWXYZ
abcdefghijklmnop
qrstuvwxyz
1234567890!?

Frutiger Roman

Typefaces
No Scale

ABCDEFGHIJKLMNOPQRSTUVWXYZ
abcdefghijklmnopqrstuvwxyz
1234567890!?

Frutiger Roman (Horizontal Scale: 84%)

**ABCDEFGHIJKLMNOPQRSTUVWXYZ
abcdefghijklmnopqrstuvwxyz
1234567890!?**

Frutiger Black (Horizontal Scale: 84%)

Typefaces
No Scale

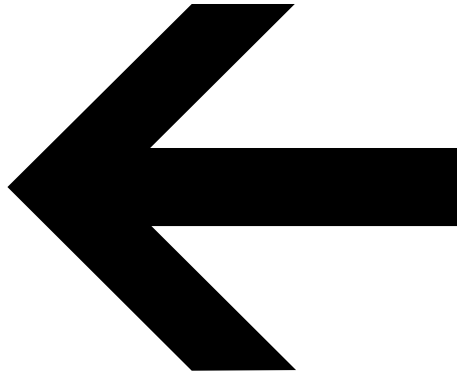

Arrow

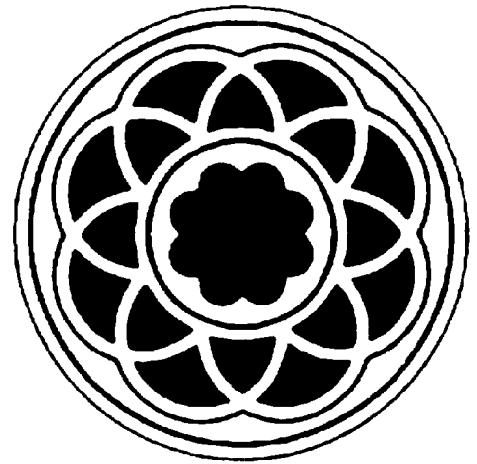

PLU Rose Window Logo



Accessibility



No Smoking

Symbol Art
No Scale

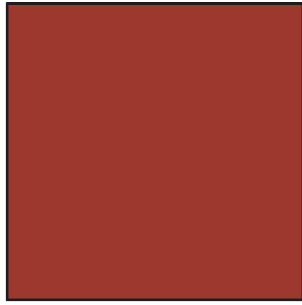

P1 Red Barn
Paint: Match Sherwin Williams 2307



P2 Mesquite Wood
Paint: Match Sherwin Williams 2161

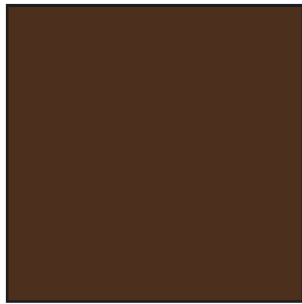

P3 Gambrel Brown
Paint: Match Sherwin Williams 2021

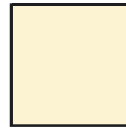

Type Color
Match Pantone 4545U

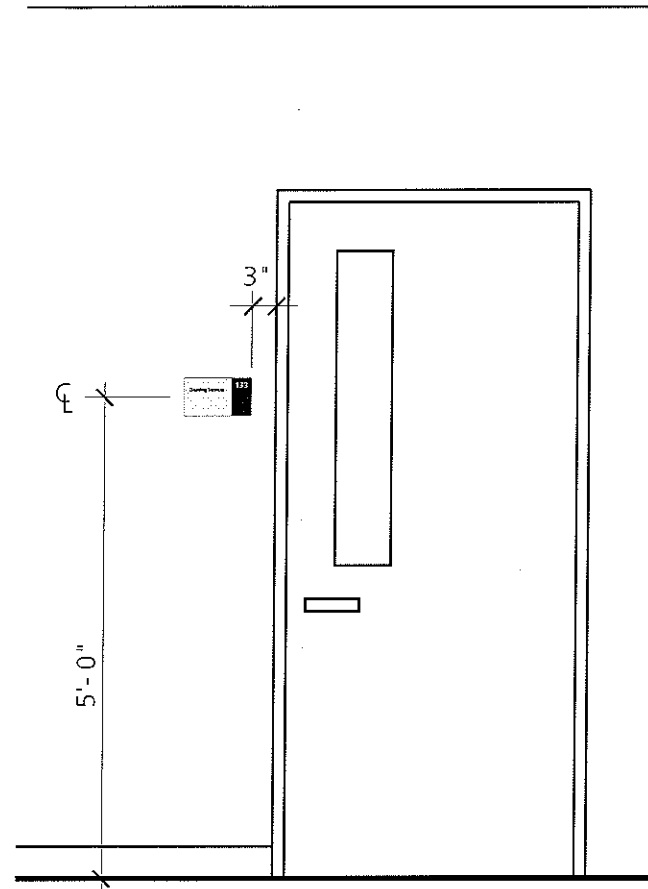

1 Mounting Condition - Sign Type J
3.1 Scale: 1/2" = 1'-0"

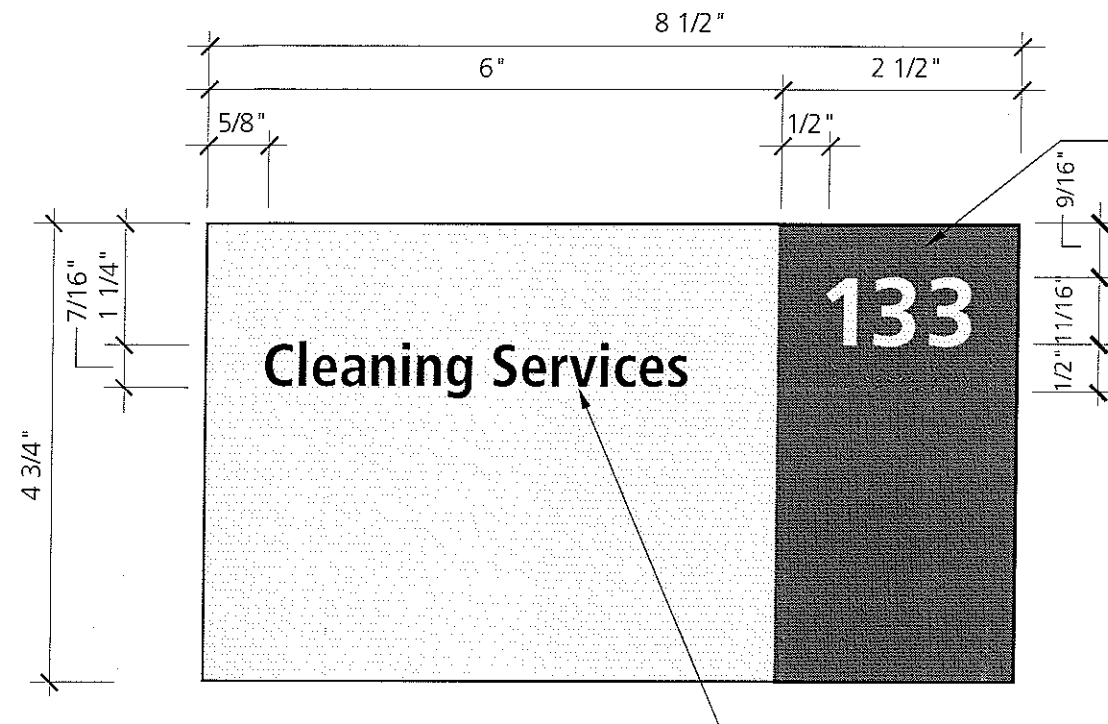

Photopolymer sign face with tactile text & braille.
Background Color: P2.
Text Color: P1.
Braille Color: Match background.
Typeface: Frutiger Bold.

Note: Sign face color does not wrap on to edges.

Clear matte finished acrylic sign face with subsurface artwork.
Background Color: P1.
Text Color: P3.
Typeface: Frutiger Bold Condensed.

2 Elevation - Sign Type J
3.1 Scale: Half Full

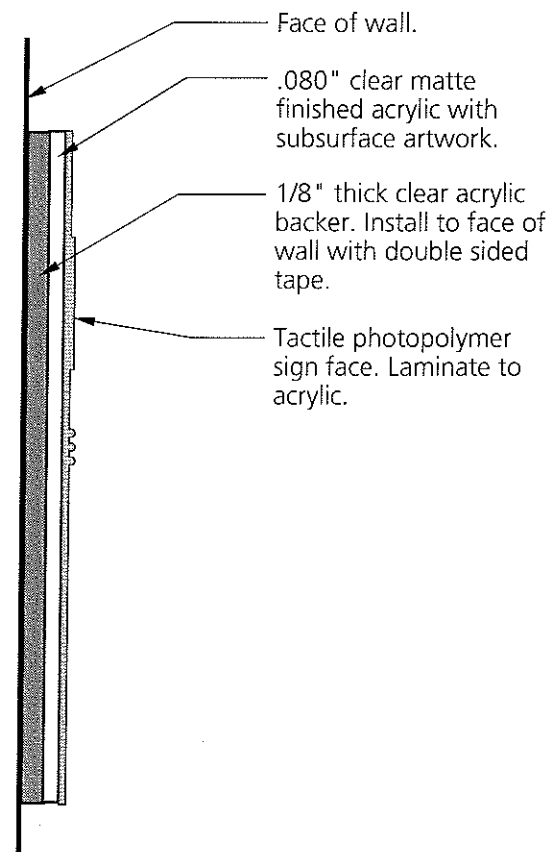

3 Section - Sign Type J
3.1 Not to Scale

Revisions

Submittal / Date
CONSTRUCTION
DOCUMENTS
03.30.01

Project
PACIFIC LUTHERAN
UNIVERSITY

XAVIER HALL
RENOVATION

Sheet Title
SIGN TYPE J

Sheet No.
3.1

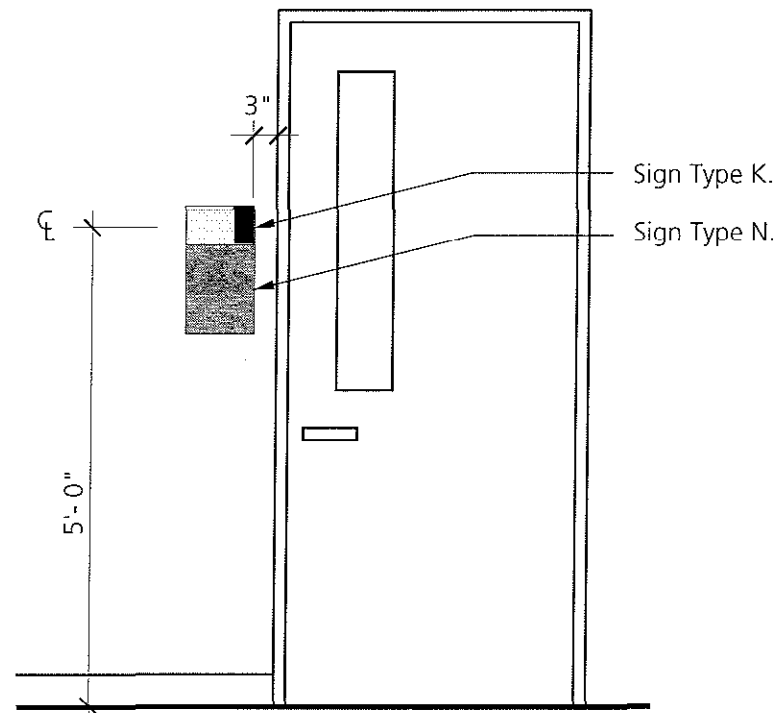

1 Mounting Condition - Sign Types K, N
3.2 Scale: 1/2" = 1'-0"

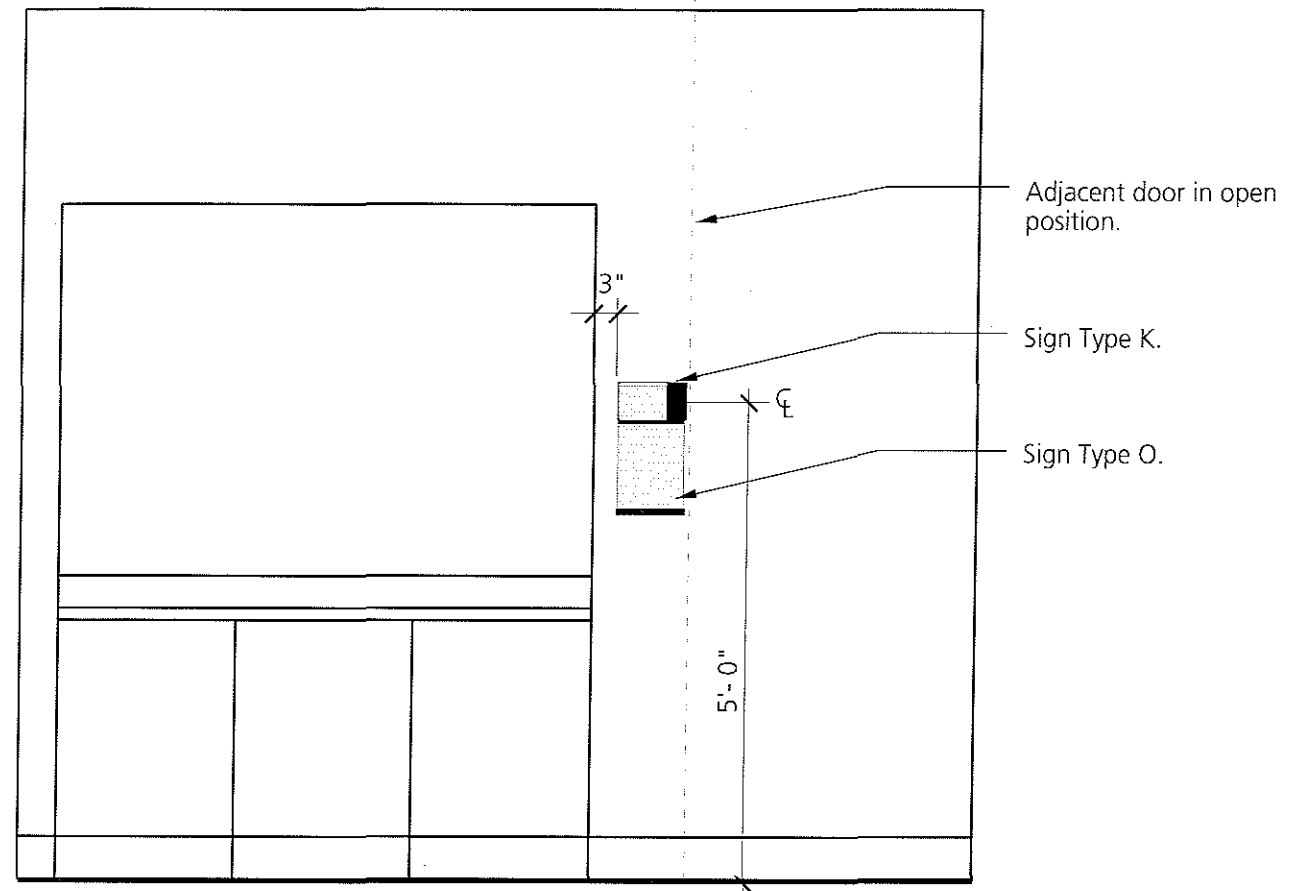

2 Mounting Condition - Signs K40, O3
3.2 Scale: 1/2" = 1'-0"

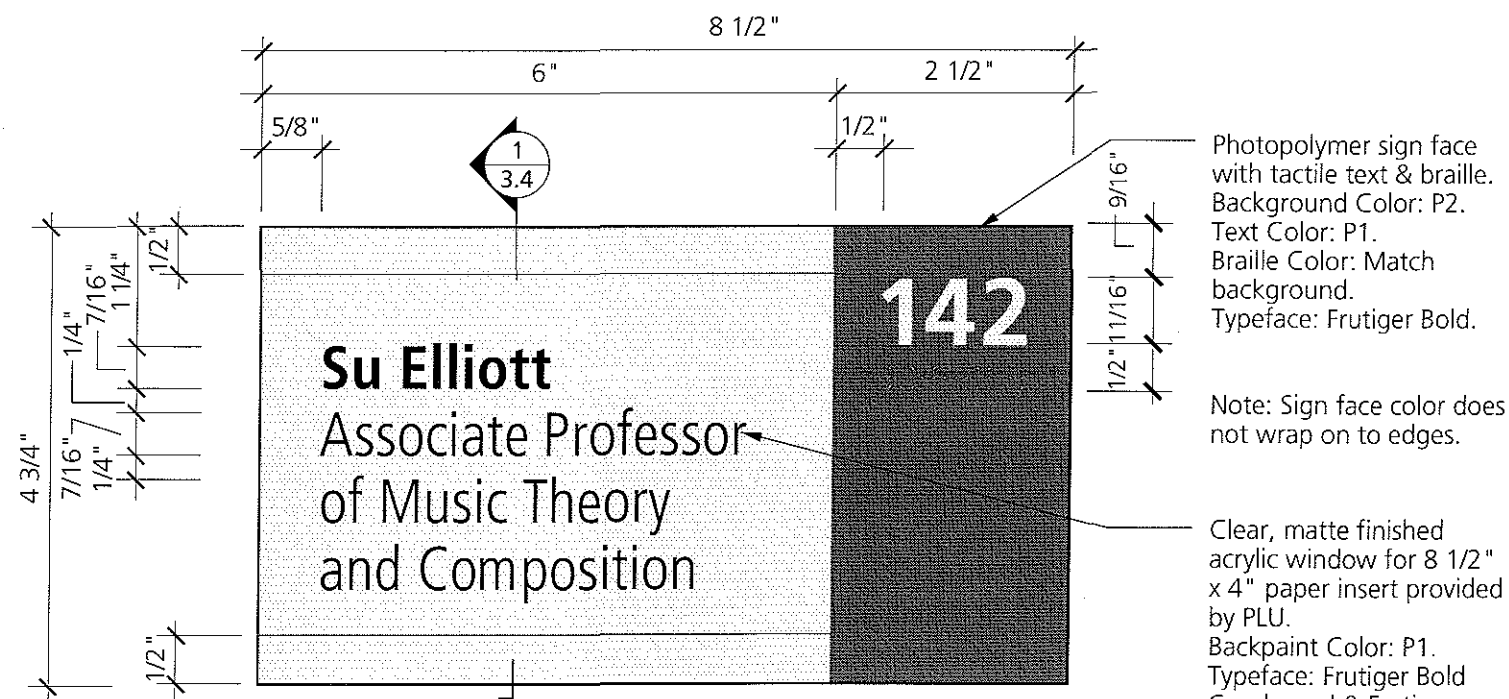

3 Elevation - Sign Type K
3.2 Scale: Half Full

Photopolymer sign face with tactile text & braille. Background Color: P2. Text Color: P1. Braille Color: Match background. Typeface: Frutiger Bold.

Note: Sign face color does not wrap on to edges.

Clear, matte finished acrylic window for 8 1/2" x 4" paper insert provided by PLU. Backpaint Color: P1. Typeface: Frutiger Bold Condensed & Frutiger Light Condensed.

Revisions

Submittal / Date
CONSTRUCTION DOCUMENTS
03.30.01

Project
PACIFIC LUTHERAN UNIVERSITY
XAVIER HALL RENOVATION

Sheet Title
SIGN TYPES K,N,O

Sheet No.
3.2

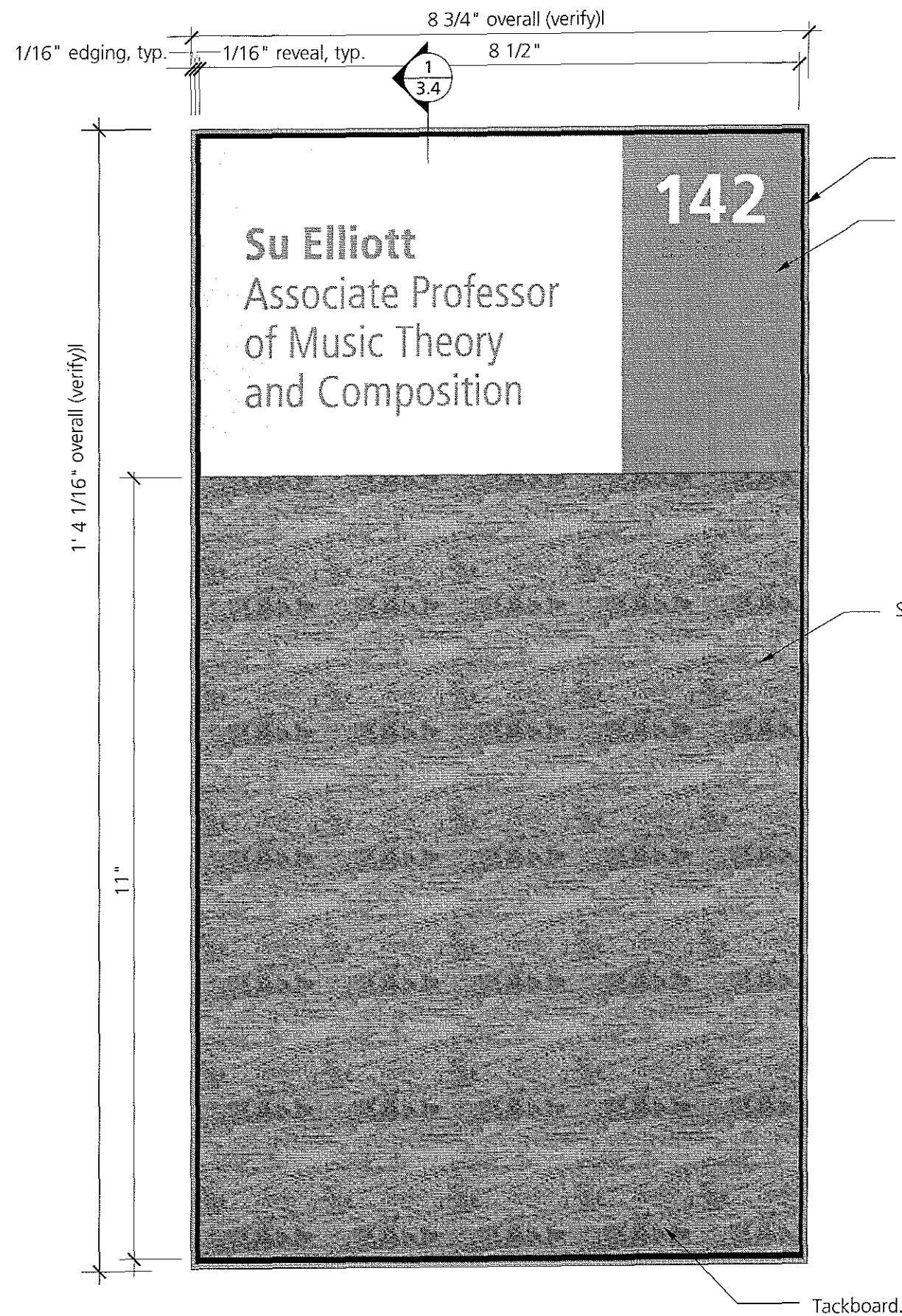

1 Elevation - Sign Type N
3.3 Scale: Half Full

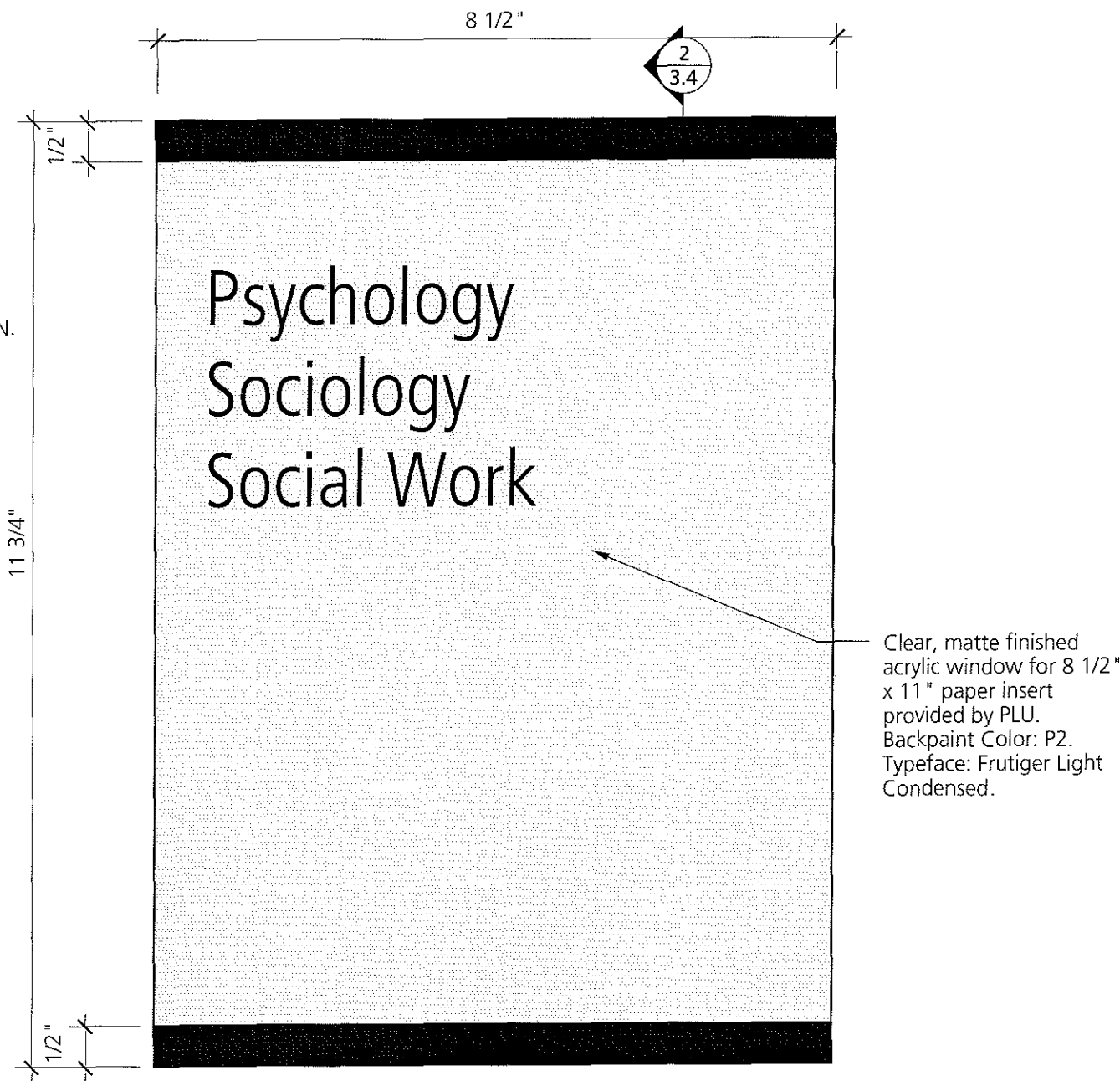

2 Elevation - Sign Type O
3.3 Scale: Half Full

Revisions

Submittal / Date
CONSTRUCTION DOCUMENTS
03.30.01

Project
PACIFIC LUTHERAN UNIVERSITY
XAVIER HALL RENOVATION

Sheet Title
SIGN TYPES K,N,O

Sheet No.
3.3

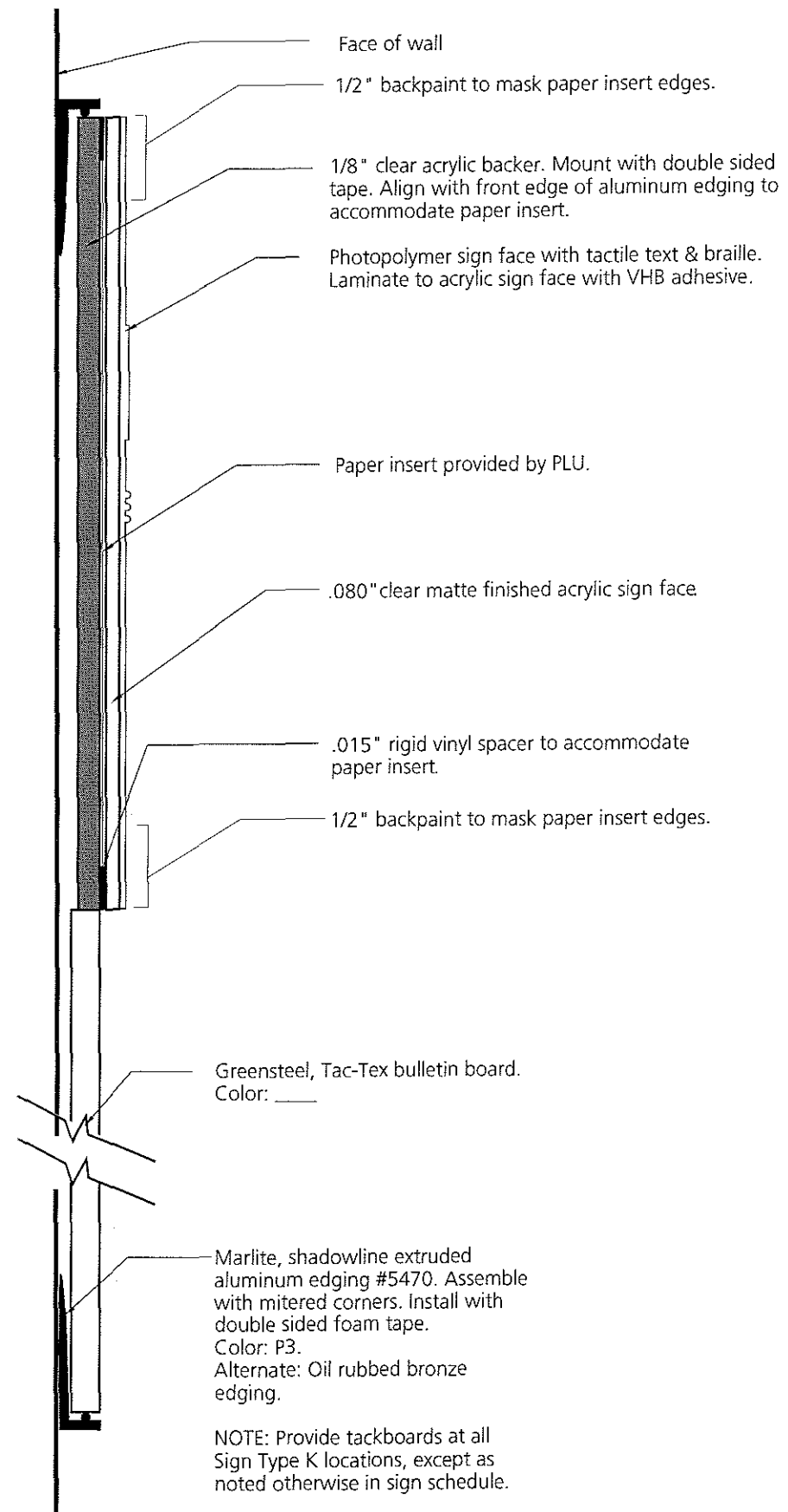

1 Section - Sign Types K, N
3.4 Scale: Full

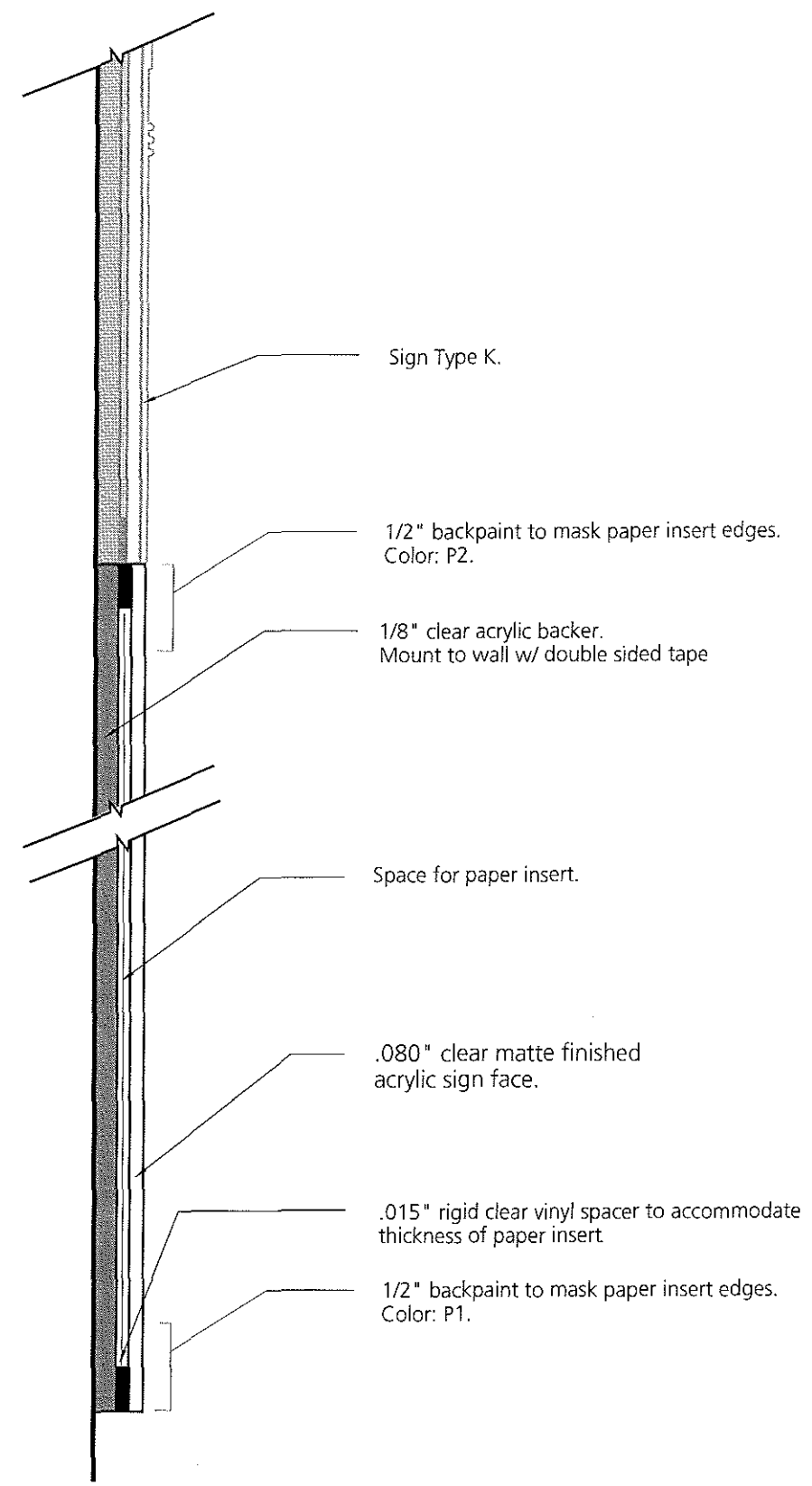

2 Section - Sign Type O
3.4 Scale: Full

Revisions

Submittal / Date

CONSTRUCTION DOCUMENTS
03.30.01

Project

PACIFIC LUTHERAN UNIVERSITY
XAVIER HALL RENOVATION

Sheet Title

SIGN TYPES K,N,O

Sheet No.

3.4

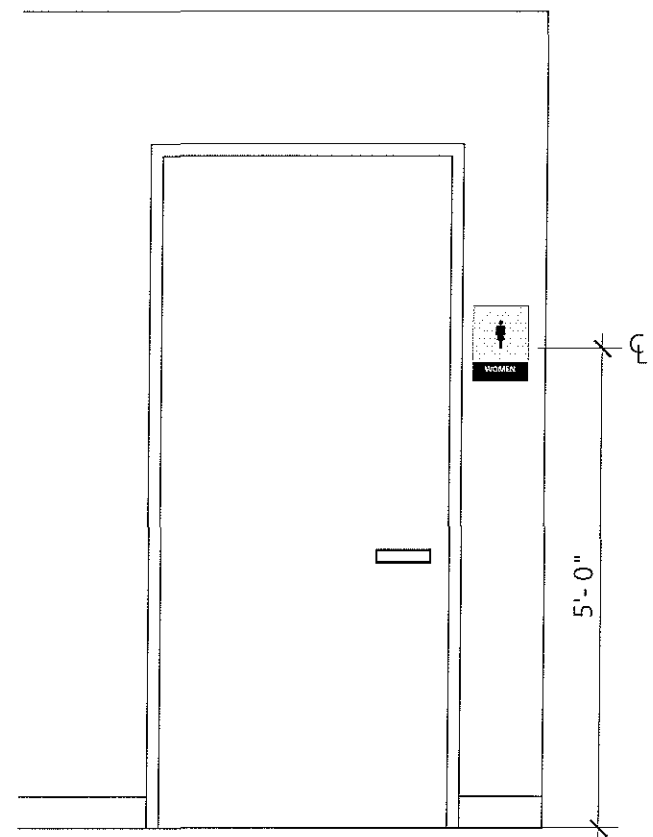

1 Mounting Condition - Sign Type L
3.5 Scale: 1/2" = 1'-0"

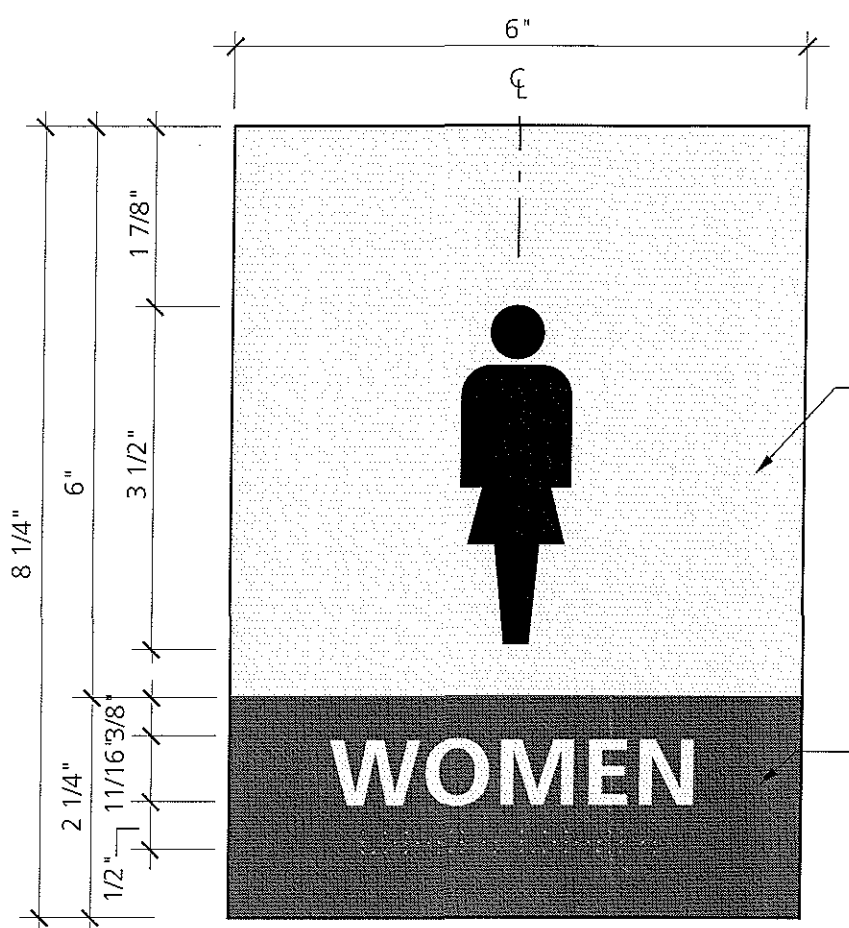

2 Elevation - Sign Type L
3.5 Scale: Half Full

Clear, matte finished acrylic with subsurface artwork. Background Color: P1. Symbol Color: P3.

Photopolymer sign face with tactile text. Background Color: P2. Text Color: P1. Braille Color: Match background. Typeface: Frutiger Bold.

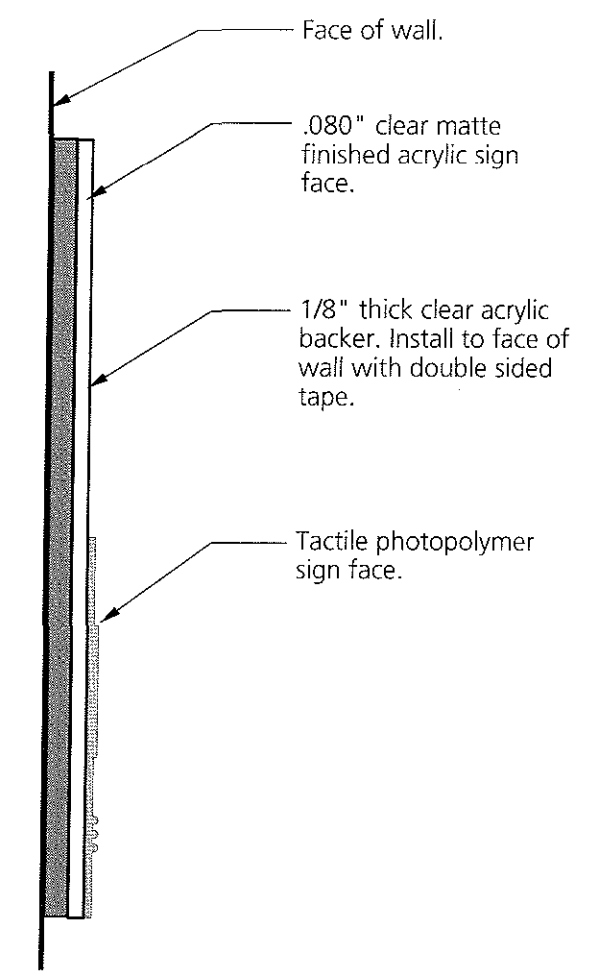

3 Section - Sign Type L
3.5 Not to Scale

Revisions

Submittal / Date
CONSTRUCTION DOCUMENTS
03.30.01

Project
PACIFIC LUTHERAN UNIVERSITY
XAVIER HALL RENOVATION

Sheet Title
SIGN TYPE L

Sheet No.
3.5

Revisions

Submission / Date

CONSTRUCTION DOCUMENTS
 03.30.01

Project

PACIFIC LUTHERAN UNIVERSITY
 XAVIER HALL RENOVATION

Sheet Title

SIGN TYPE P

Sheet No.

3.6

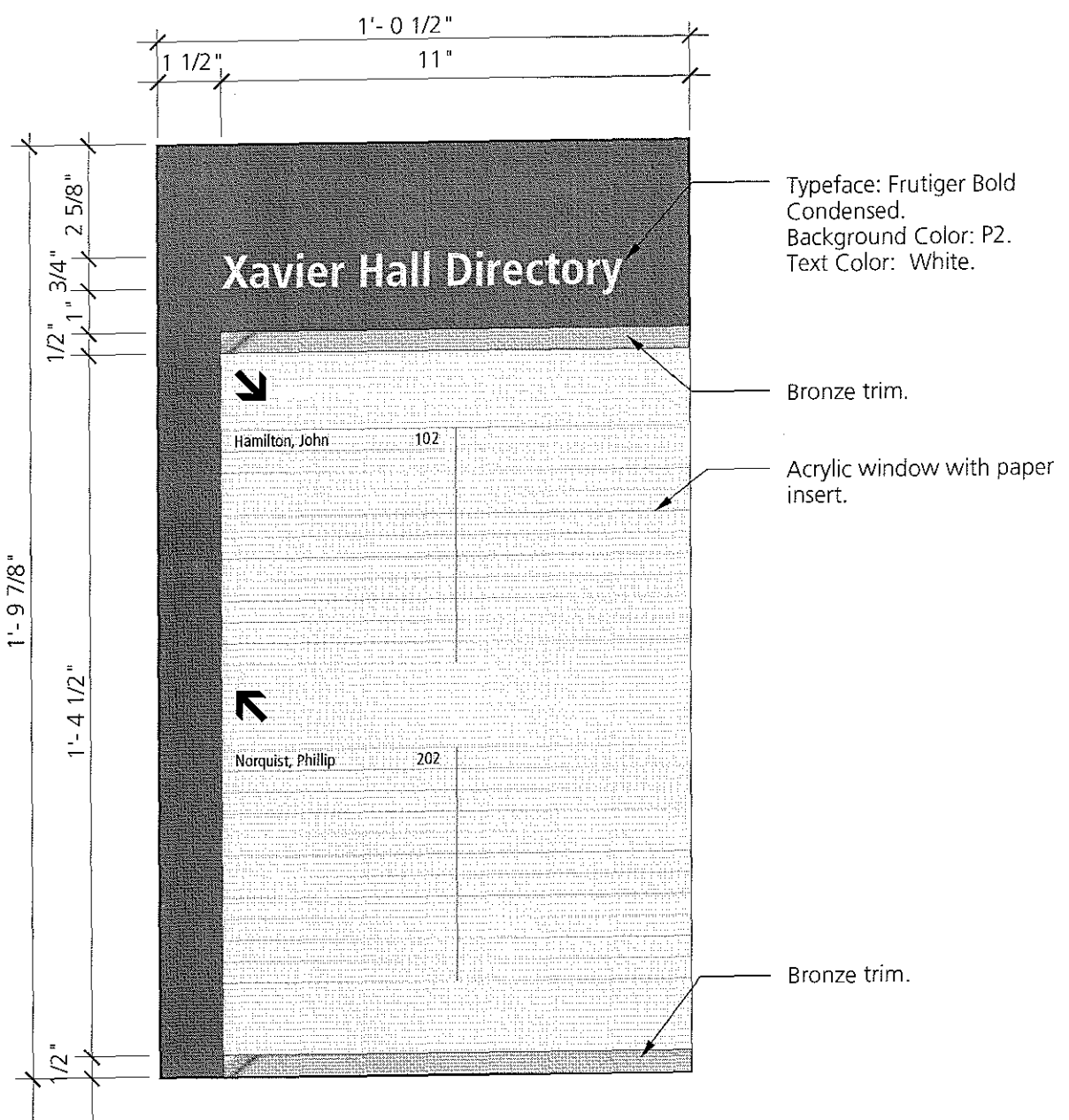

1 Elevation - Sign Type P
 3.6 Scale: 3"=1'-0"

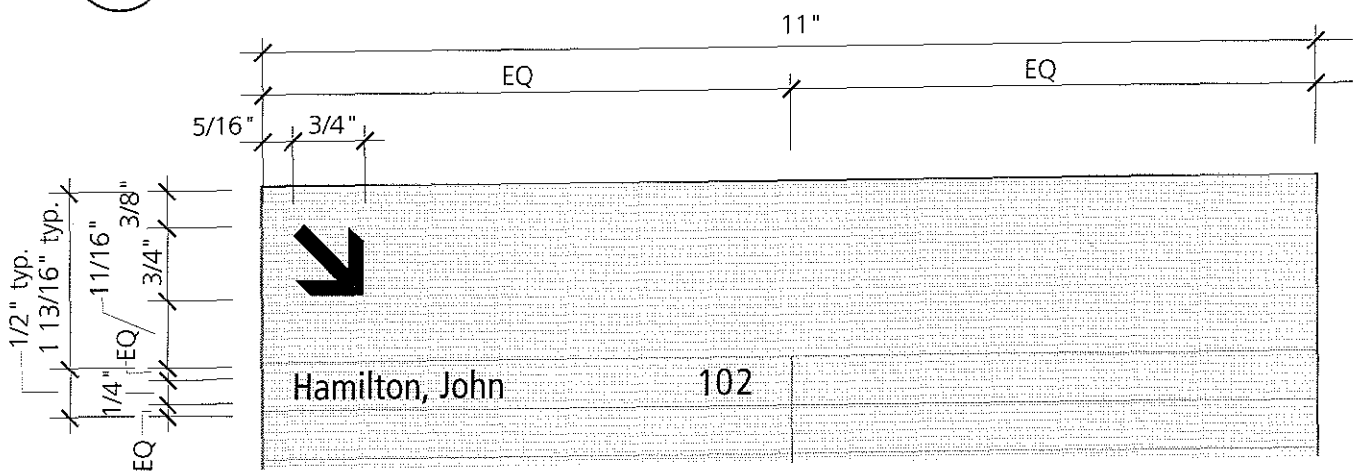

2 Paper Insert Detail - Sign Type P
 3.6 Scale: Half Full

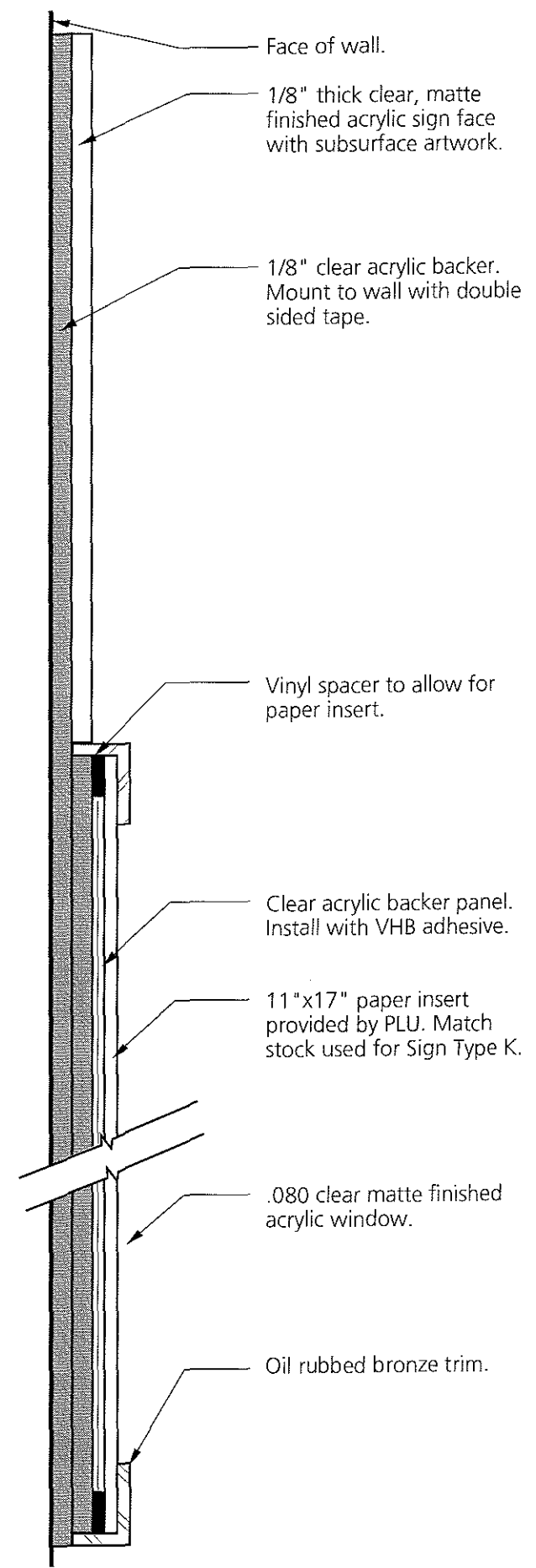

3 Section - Sign Type P
 3.6 Scale: Full

Visual Communications
319 SW Washington St.
Suite 820
Portland, Oregon 97204
T 503.223.5953
F 503.223.8076

Revisions

Submittal / Date
CONSTRUCTION
DOCUMENTS
03.30.01

Project
PACIFIC LUTHERAN
UNIVERSITY
XAVIER HALL
RENOVATION

Sheet Title
SIGN TYPE Q

Sheet No.
3.7



1 Mounting Condition - Signs Q-1, Q-4
3.7 Scale: 1/2" = 1'-0"

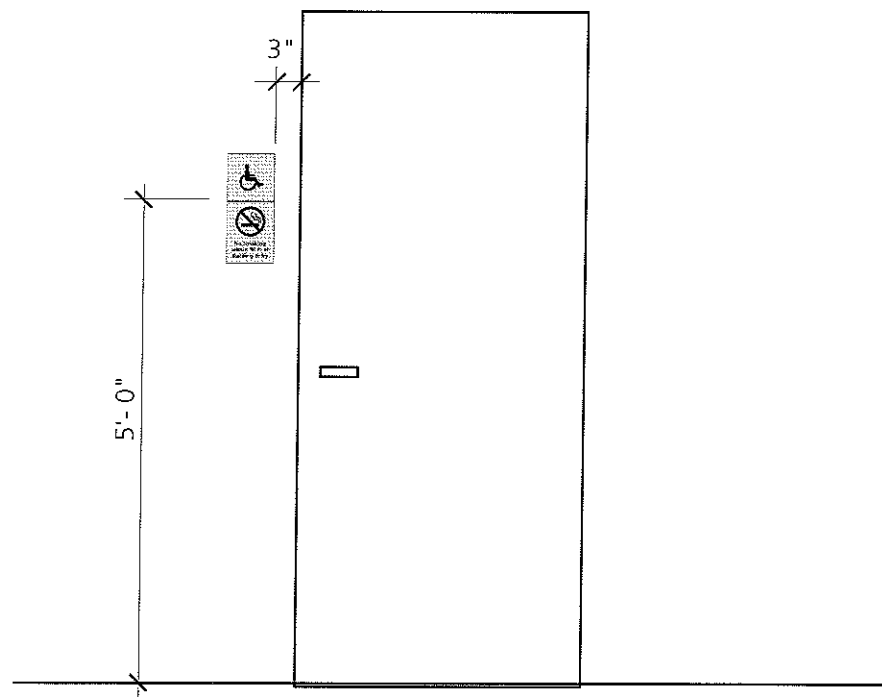

2 Mounting Condition - Signs Q-2, Q-3
3.7 Scale: 1/2" = 1'-0"

Visual Communications
 319 SW Washington St.
 Suite 820
 Portland, Oregon 97204
 T 503.223.5953
 F 503.223.8076

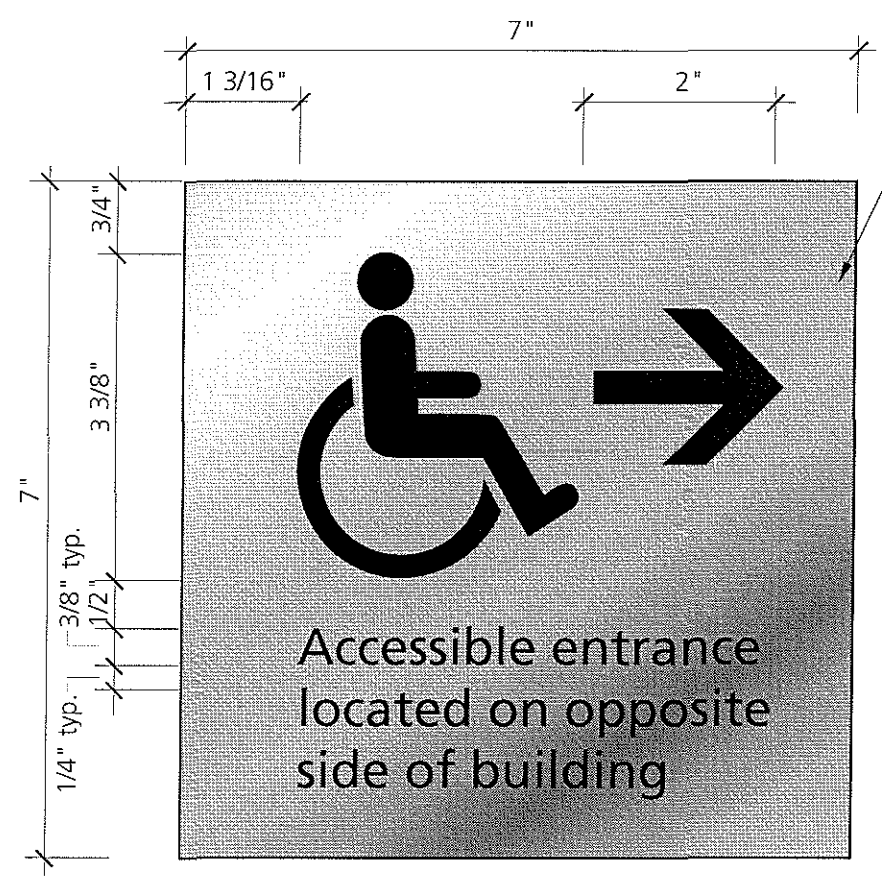

.080" thick stainless steel sign panel with etched & infilled message.
 Finish: Fine satin, horizontal grain.
 Infill color: Black, matte finish.
 Typeface: Frutiger Roman.

1 Elevation - Sign Q-1
 3.8 Scale: Half Full

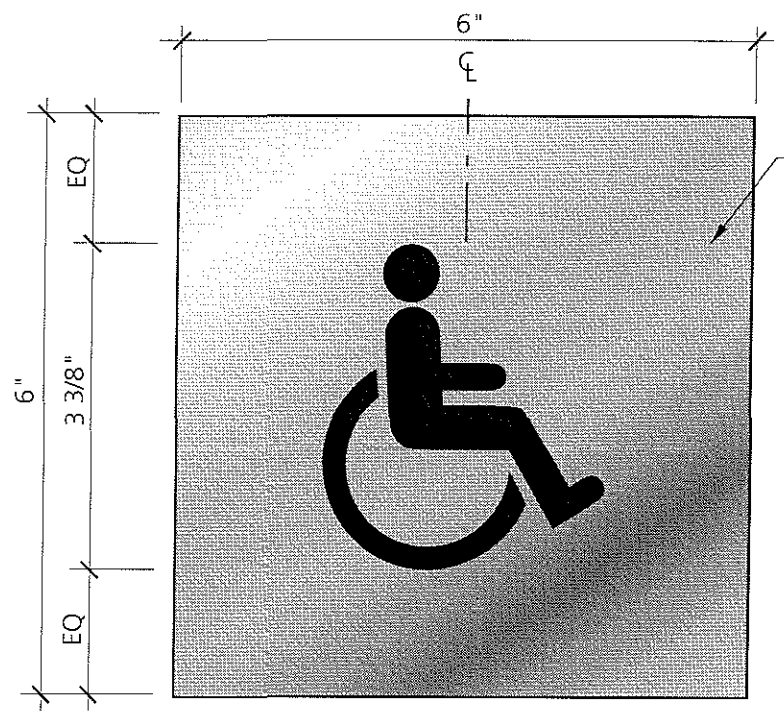

.080" thick stainless steel sign panel with etched & infilled symbol.
 Finish: Fine satin, horizontal grain.
 Infill color: Black, matte finish.

2 Elevation - Sign Q-2
 3.8 Scale: Half Full

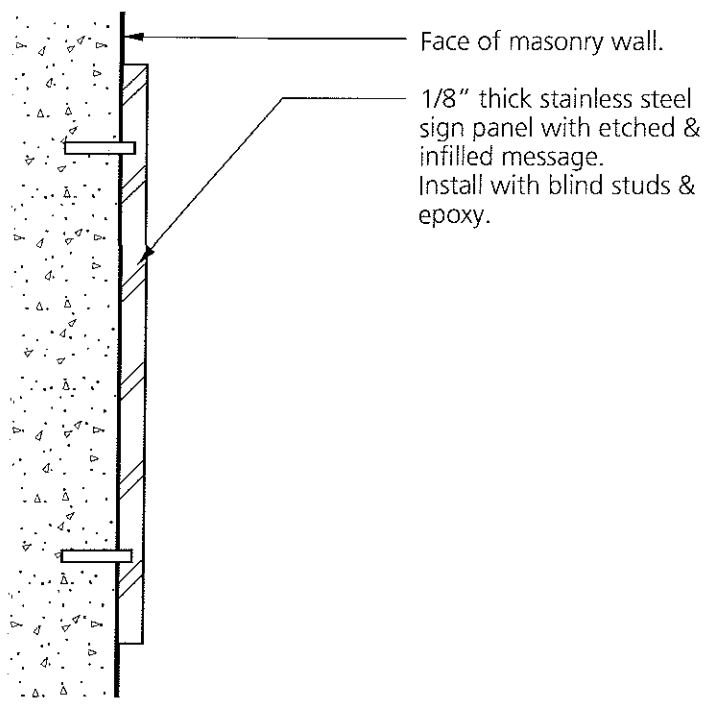

Face of masonry wall.
 1/8" thick stainless steel sign panel with etched & infilled message.
 Install with blind studs & epoxy.

3 Section - Sign Type Q
 3.8 Not to Scale



.080" thick stainless steel sign panel with etched & infilled message & symbol.
 Finish: Fine satin, horizontal grain.
 Infill color: Black, matte finish.
 Typeface: Frutiger Roman.

4 Elevation - Signs Q-3, Q-4
 3.8 Scale: Half Full

Revisions

Submittal / Date
 CONSTRUCTION DOCUMENTS
 03.30.01

Project
 PACIFIC LUTHERAN UNIVERSITY
 XAVIER HALL RENOVATION

Sheet Title
 SIGN TYPE Q

Sheet No.
 3.8

Visual Communications
319 SW Washington St.
Suite 820
Portland, Oregon 97204
T 503.223.5953
F 503.223.8076

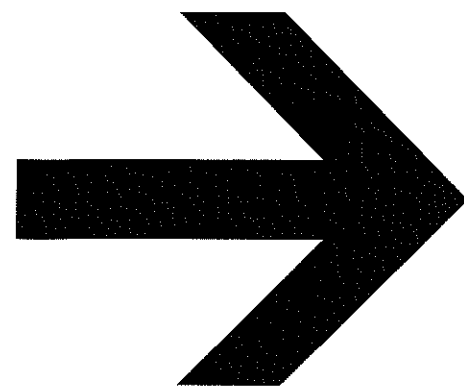
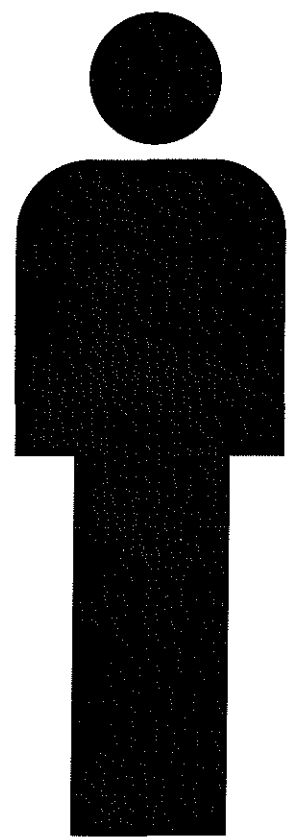
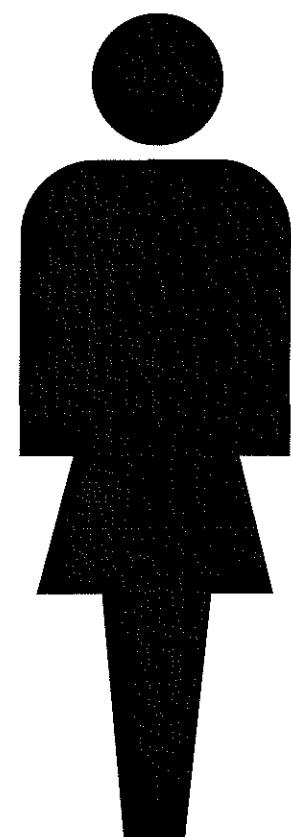

Revisions

Submittal / Date
CONSTRUCTION
DOCUMENTS
03.30.01

Project
PACIFIC LUTHERAN
UNIVERSITY

XAVIER HALL
RENOVATION

Sheet Title
SYMBOL ART

Sheet No.
3.9

1 Symbol Art
3.9 No Scale

ABCDEFGHIJKLM
NOPQRSTUVWXYZ
abcdefghijklmno
pqrstuvwxyz
1234567890!?

Frutiger Light Condensed

ABCDEFGHIJKLM
NOPQRSTUVWXYZ
abcdefghijklmno
pqrstuvwxyz
1234567890!?

Frutiger Bold Condensed

ABCDEFGHIJKLM
NOPQRSTUVWXYZ
abcdefghijklmno
pqrstuvwxyz
1234567890!?

Frutiger Bold

ABCDEFGHIJKLM
NOPQRSTUVWXYZ
abcdefghijklmno
pqrstuvwxyz
1234567890!?

Frutiger Roman

Revisions

Submittal / Date
CONSTRUCTION
DOCUMENTS
03.30.01

Project
PACIFIC LUTHERAN
UNIVERSITY
XAVIER HALL
RENOVATION

Sheet Title
TYPEFACES

Sheet No.
3.10

SECTION 10522

FIRE EXTINGUISHERS, CABINETS, AND ACCESSORIES

PART 1 – GENERAL

1.01 REFERENCES

- A. NFPA 10 – Portable Fire Extinguishers and fire protection cabinets.

1.02 SUBMITTALS

- A. Section 01330 – Submittals: Procedures for submittals
- B. Product Data: Provide extinguisher operational features, color and finish, anchorage details, rough-in measurements, location and details.
 - 1. Fire Extinguishers: Include rating and classification.
 - 2. Cabinets: Include door hardware, cabinet type, trim style, panel style, and details of installation.
 - 3. LEED™ Documentation:
 - a. Indicate whether each product contains post-consumer or post-industrial recycled materials, or both.
 - b. Indicate location of manufacture, highlighting those materials manufactured within a 500-mile radius.
- C. Record Documents for LEED™:
 - 1. Show use on LEED™ Calculator Spreadsheet of Section 01101 LEED™ Program Requirements.
 - 2. Show Contractor's official stamp indicating specific products used in the Work.

1.03 ENVIRONMENTAL REQUIREMENTS

- A. Do not install extinguishers when ambient temperature may cause freezing of extinguisher ingredients.

1.04 **QUALITY ASSURANCE**

- A. NFPA Compliance: Fabricate and label fire extinguishers to comply with NFPA 10, "Standard for Portable Fire Extinguishers."
- B. Fire Extinguishers: Listed and labeled for type, rating, and classification by an independent testing agency acceptable to authorities having jurisdiction.

1.05 **ALTERNATES**

See Section 01230 for bidding alternates affecting the Work of this Section.

1.06 **COLORS**

- A. Colors are specified in Colors/Materials Schedule.

1.07 **SUSTAINABLE BUILDING REQUIREMENTS**

See Section 01011 for sustainable building requirements affecting the Work of this Section.

PART 2 – PRODUCTS

2.01 **MANUFACTURERS**

- A. Cold-Rolled Steel Sheet: ASTM A 366/A 366M carbon steel, commercial quality, stretcher leveled, temper rolled.
- B. Select products that contain recycled content. Products with post-consumer recycled content are preferred.
- C. Select products that are manufactured/assembled within a 500-mile radius of the Project site.
- D. Acceptable Manufacturers:
 - 1. J.L. Industries
 - 2. Larsen's Manufacturing Co.
 - 3. Potter – Roemer
 - 4. Substitutions: Under provisions of Section 01600

5. Specifications are based on products manufactured by Larsen's.

2.02 PORTABLE FIRE EXTINGUISHERS

- A. General: Provide fire extinguishers for each cabinet and other locations indicated.
- B. Multipurpose Dry-Chemical Type: UL-rated 1-A:10-B:C, 2 -1/2 lb nominal capacity, in enameled-steel container.

2.03 CABINETS

- A. Larsen's Model No. 2409-SR (Semi-Recessed), Duo break glass door style with lock and no handle, clear anodized aluminum construction, with tempered glass. Provide Series "B" mounting bracket for fire extinguisher inside cabinet so that top of extinguisher is clearly visible with door closed.

PART 3 – EXECUTION

3.01 EXAMINATION

- A. Section 01310 – Coordination and Meetings: Verification of existing conditions before starting work.
- B. Verify rough openings for cabinet are correctly sized and located.

3.02 INSTALLATION

- A. Examine roughing-in for cabinets to verify actual locations of piping connections before cabinet installation.
- B. Examine walls and partitions for suitable framing depth and blocking where recessed and semi-recessed cabinets are to be installed.
- C. Examine fire extinguishers for proper charging and tagging. Remove and replace damaged, defective, or undercharged units.
- D. Install in locations and at mounting heights indicated or, if not indicated, at heights acceptable to authorities having jurisdiction.
 1. Prepare recesses for cabinets as required by type and size of cabinet and trim style.

2. Fasten mounting brackets to structure and cabinets, square and plumb.
 3. Fasten cabinets to structure, square and plumb.
- E. Adjust cabinet doors that do not swing or operate freely.
 - F. Refinish or replace cabinets and doors damaged during installation.

END OF SECTION

SECTION 10800

TOILET AND BATH ACCESSORIES

PART 1 – GENERAL

1.01 REFERENCES

- A. ANSI A117.1 – Safety Standards for the Handicapped.
- B. ASTM A167 – Stainless and Heat-Resisting Chromium-Nickel Steel Plate, Sheet, and Strip.
- C. ASTM A269 – Seamless and Welded Austenitic Stainless Steel Tubing for General Service.
- D. ASTM A366 – Steel, Carbon, Cold-Rolled Sheet, Commercial Quality.
- E. ASTM B456 - Electrodeposited Coatings of Copper Plus Nickel Plus Chromium and Nickel Plus Chromium.
- F. NEMA LD-3 – High Pressure Decorative Laminates.

1.02 SUBMITTALS

- A. Submit under provisions of Section 01330.
- B. Product Data: Include construction details, material descriptions and thicknesses, dimensions, profiles, fastening and mounting methods, specified options, and finishes for each type of accessory specified.
- C. Setting Drawings: For cutouts required in other work; include templates, substrate preparation instructions, and direction for preparing cutouts and installing anchoring devices.
- D. Samples: Submit three (3) samples, at least 6" x 9" of stainless steel of the finish proposed.
- E. Maintenance Data: For accessories to include in maintenance manuals specified in Division 1. Provide lists of replacement parts and service recommendations. Submit operating instructions and keys required for each type of equipment and lock.

1.03 REGULATORY REQUIREMENTS

- A. Source Limitations: Provide products of same manufacturer for each type of accessory unit and for units exposed to view in same areas, unless otherwise approved by Architect.
- B. Product Options: Accessory requirements, including those for materials, finishes, dimensions, capacities, and performance, are established by specific products indicated in the Toilet and Bath Accessory Schedule.
 - 1. Other manufacturers' products with equal characteristics may be considered. See Division 1 Section "Substitutions."

1.04 COORDINATION

- A. Coordinate the Work with the placement of internal wall reinforcement and reinforcement of toilet partitions to receive anchor attachments.
- B. Coordinate accessory locations with other Work to prevent interference with clearances required to access by disabled persons, proper installation, adjustment, operation, cleaning, and servicing of accessories.

1.05 SEQUENCING AND SCHEDULING

- A. Coordinate the Work of this Section with Section 06112 for the placement of blocking to receive anchor attachments. Contractor to provide blocking for all accessories and toilet compartments, including Owner furnished accessories.

1.06 KEYING

- A. Master key all accessories.

1.07 COLORS

- A. Colors are specified in Colors/Materials Schedule.

1.08 ALTERNATES

See Section 01230 for bidding alternates affecting the Work of this Section.

1.09 WARRANTY

- A. General Warranty: Special warranty specified in this Article shall not deprive Owner of other rights Owner may have under other provisions of the Contract

Documents and shall be in addition to, and run concurrent with, other warranties made by Contractor under requirements of the Contract Documents.

- B. Provide five (5) year warranty for mirrors, against silver spoilage.

1.10 SUSTAINABLE BUILDING REQUIREMENTS

See Section 01011 for sustainable building requirements affecting the Work of this Section.

PART 2 – PRODUCTS

2.01 MANUFACTURERS

- A. Subject to conformance with Specification requirements, the following manufacturers are acceptable:
 - 1. American Specialties
 - 2. Bobrick Washroom Equipment, Inc.
 - 3. Bradley
- B. Substitutions: Under provisions of Section 01600.

2.02 MATERIALS

- A. Stainless Steel: ASTM A 666, Type 304, with No. 4 finish (satin), in 0.0312 – inch minimum nominal thickness, unless otherwise indicated.
- B. Brass: ASTM B 19, leaded and unleaded flat products; ASTM B 16, rods, shapes, forgings, and flat products with finished edges; ASTM B 30, castings.
- C. Sheet Steel: ASTM A 366/A 366M, cold rolled, commercial quality, 0.0359 – inch minimum nominal thickness; surface preparation and metal pretreatment as required for applied finish.
- D. Galvanized Steel Sheet: ASTM A 653/A 653Nm G60.
- E. Chromium Plating: ASTM B 456, Service Condition Number SC 2 (moderate service), nickel plus chromium electrodeposited on base metal.

- F. Baked-Enamel Finish: Factory-applied, gloss-white, baked-acrylic-enamel coating.
- G. Galvanized Steel Mounting Devices: ASTM A 153/A 153M, hot-dip galvanized after fabrication.
- H. Fasteners: Screws, bolts, and other devices of same material as accessory unit, tamper and theft resistant when exposed, and of galvanized steel when concealed.

2.03 FABRICATION

- A. General: One, maximum 1 – ½ inch diameter, unobtrusive stamped manufacturer logo, as approved by Architect, is permitted on exposed face of accessories. On interior surface not exposed to view or back surface of each accessory, provide printed, waterproof label or stamped nameplate indicating manufacturer's name and product model number.
- B. General: Names or labels are not permitted on exposed faces of accessories. On interior surface not exposed to view or on back surface of each accessory, provide printed, waterproof label or stamped nameplate indicating manufacturer's name and product model number.
- C. Surface-Mounted Toilet Accessories: Unless otherwise indicated, fabricate units with tight seams and joints, and exposed edges rolled. Hang doors and access panels with continuous stainless-steel hinge. Provide concealed anchorage where possible.
- D. Recessed Toilet Accessories: Unless otherwise indicated, fabricate units of all-welded construction, without mitered corners. Hang doors and access panels with full-length, stainless-steel hinge. Provide anchorage that is fully concealed when unit is closed.
- E. Keys: Provide universal keys for internal access to accessories for servicing and resupplying. Provide minimum of six (6) keys to Owner's representative.

2.04 FINISHES

- A. Galvanizing: ASTM A123 to 2.0 oz/sq. yd. Galvanize ferrous metal and fastening devices.
- B. Shop Primed Ferrous Metals: Pre-treat and clean, spray apply one (1) coat primer and bake.

- C. Enamel: Pre-treat to clean condition, apply one (1) coat primer and minimum two (2) coats epoxy baked enamel.
- D. Chrome/Nickel Plating: ASTM B456, satin finish.
- E. Stainless Steel: No. 4 satin luster finish.
- F. Back paint components where contact is made with building finishes to prevent electrolysis.

2.05 **ACCESSORY TYPES/ACCESSORIES**

- A. Toilet Paper Holder: Provided by Owner, installed by Contractor.
- B. Soap Dispenser: Provided by Owner, installed by Contractor.
- C. Stainless Steel Trim Mirror: Tempered Glass Mirror with Stainless Steel Channel Frame: B-165 2436.
- D. Paper Towel Dispenser: Provided by Owner, installed by Contractor.
- E. Grab Bars: 5861-99 Series.
- F. Sanitary Napkin Disposal: Rochester Midland, #25032000.
- G. Seat Cover Dispenser: Provided by Owner, installed by Contractor.
- H. Baby Changing Station: Koala Kare Products, KB100-00ST, "CREAM", KB100-01ST, "GREY."

PART 3 – EXECUTION

3.01 **EXAMINATION**

- A. Verify that site conditions are ready to receive work and dimensions are as indicated on shop drawings.
- B. Verify exact location of accessories for installation.

3.02 **PREPARATION**

- A. Deliver inserts and rough-in frames to site for timely installation.

- B. Provide templates and rough-in measurements as required.

3.03 **INSTALLATION**

- A. Install accessories in accordance with manufacturers' instructions and ANSI A117.1.
- B. Install plumb and level, securely and rigidly anchored to substrate.
- C. Install grab bars to withstand a downward load of at least 250 lbf, when tested according to method in ASTM F 446.

3.04 **ADJUSTING AND CLEANING**

- A. Adjust all moving parts to operate perfectly.
- B. Clean all exposed surfaces.
- C. Leave instructions free of imperfections; premises free of any residue of Work of this Section.

END OF SECTION

SECTION 10999

MISCELLANEOUS SPECIALTIES

PART 1 – GENERAL

1.01 SUBMITTALS

- A. Product Data and Samples: Submit per Section 01330.

1.02 DELIVERY, STORAGE, AND HANDLING

- A. In accordance with Section 01600 and the following:
 - 1. Acceptance at Site:
 - a. Verify undamaged condition.
 - 2. Protection (prior to installation):
 - a. Store out of harm's way.
 - 3. Handle to prevent marring finishes.

1.03 SEQUENCING/SCHEDULING

- A. Phase in properly with Construction Schedule per Section 01330.

1.04 COLORS

- A. Colors are specified in Colors/Materials Schedule.

1.05 ALTERNATES

See Section 01230 for bidding alternates affecting the Work of this Section.

1.06 SUSTAINABLE BUILDING REQUIREMENTS

See Section 01011 for sustainable building requirements affecting the Work of this Section.

PART 2 – PRODUCTS

2.01 WALK-OFF MAT

- A. Provide and install Mat's Inc. "Ultra Entry" foot grille system.

2.02 PROJECTION SCREEN – IN FOCUS

- A. Furnish and install "SC-PD-120", manual projection screen, 120" diagonal.
- B. Furnish and install "SC-PD-100", manual projection screen, 100" diagonal.

2.03 PROJECTOR – IN FOCUS

- A. Furnish and install "IN-36", projector.

2.04 DISHWASHER

- A. Provide and install Bosch #SHU66CO (2). Stainless steel faced dishwasher.

2.05 BUTT GLAZED GLAZING SYSTEM

- A. Provide and install Blumcraft Series 1301 Sidelite system with C4000 header and "Clad" base channel. Provide 3/4 "thick laminated safety glass as recommended by manufacturer.

2.06 ROOF HATCH

- A. Provide and install "Bilco" Roof Hatch, type [] . Dimensions as indicated on drawings.

PART 3 – EXECUTION

3.01 INSPECTION

- A. Verify installation conditions as satisfactory to receive Work of this Section. Do not install until any unsatisfactory conditions are corrected. Beginning work constitutes acceptance of conditions as satisfactory.

3.02 PREPARATION

- A. Protect surrounding surfaces to preclude damage from Work of this Section.

3.03 **INSTALLATION**

- A. Install in accordance with Specifications and manufacturer's directions. Where these may be in conflict, the more stringent requirements apply.

END OF SECTION